

Stirnradgetriebemotoren BC

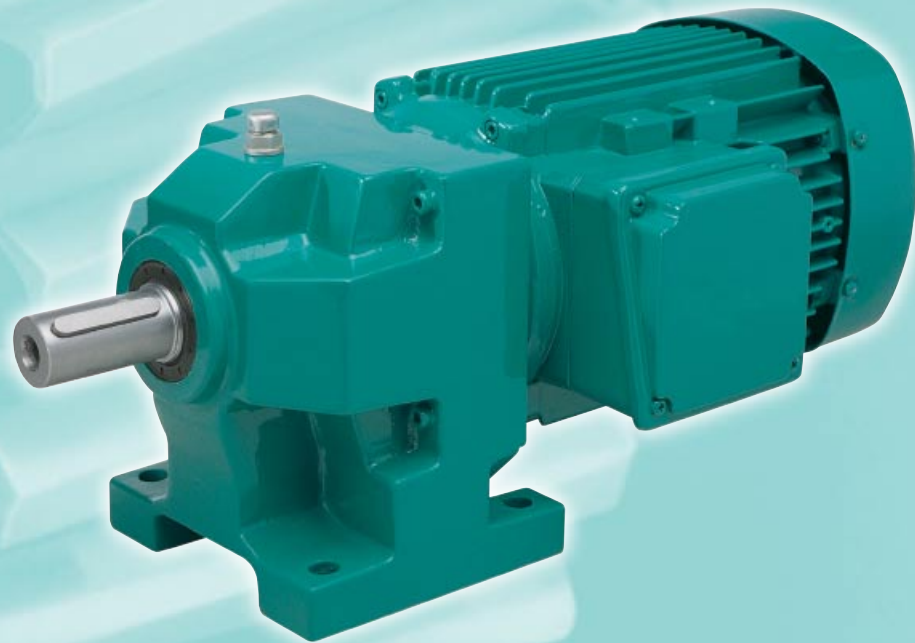

Helical Geared Motors BC

BOCKWOLDT
GETRIEBEMOTORENWERK

Geschäftsbedingungen

Unseren Lieferungen und Leistungen liegen die Ihnen bekannten „Allgemeinen Lieferbedingungen für Erzeugnisse und Leistungen der Elektroindustrie“ sowie unsere Verkaufs – und Lieferbedingungen, die Sie mit jedem Angebot bzw. jeder Auftragsbestätigung erhalten, zugrunde. Änderung von Katalogangaben, insbesondere der Maße, bleiben vorbehalten. Alle Gewichte sowie die aufgeführten Nennströme sind unverbindliche Angaben.

Reklamationen über gelieferte Waren sind innerhalb von 8 Tagen nach Erhalt der Ware schriftlich an unsere Adresse bekanntzugeben.

Spätere Beanstandungen können nicht berücksichtigt werden.

Kataloge

Durch diese Ausgabe verlieren alle bisherigen Kataloge über BC Stirnrad-Getriebemotoren und BC Stirnrad-Getriebe ihre Gültigkeit

Januar 2005

Terms and Conditions of Business

Goods and services supplied by us are subject to the „General Conditions for Supply of Products and Services of the Electrical Manufacturing Industry“ as well as the company's „General Terms and Conditions“ furnished. All catalogue details, especially the measurements given, are subject to change without prior notice. Weight details as well as rated currents quoted are not binding

With regard to our effected deliveries, only written complaints sent to our address within 8 days after receipt of the goods can be taken into consideration.

It is not possible for us to consider objections raised at a later date.

Catalogues

This edition supplants all previous catalogues of BC Helical Geared Motors and BC Helical Gear Boxes.

January 2005

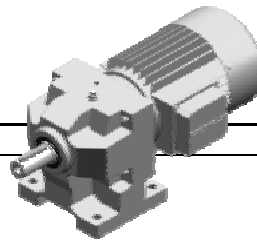

A.1 Inhaltsverzeichnis
Contents

A	Allgemeine technische Erläuterungen.....	General Technical Explanations.....	1
	A.1 Inhaltsverzeichnis.....	Contents.....	1
	A.2 Einleitung.....	Introduction.....	2
B	Auswahl des Antriebes.....	Drive Selection.....	3
	B.1 Daten zur Antriebsauslegung.....	Drive Selection Data.....	3
	B.2 Typenbezeichnung BC Stirnradgetriebe.....	Type Designation: BC Helical Gear Boxes.....	4
	B.3 Typenbezeichnung Motor.....	Type Designation: Motor.....	5
	B.4 Betriebsfaktor.....	Service Factors.....	6
	B.5 Radial- und Axialkräfte.....	Overhung Loads and Thrust Loads.....	7
	B.6 Einbaulagen.....	Mounting Positions.....	8
	B.7 Position des Klemmenkastens.....	Position of the Terminal Box.....	9
	B.8 Schmierstoffe.....	Lubricants.....	10
	B.9 ATEX Checkliste.....	ATEX Checklist.....	11
C	Auswahllisten für BC Stirnradtriebemotoren... 	Selection Lists for BC Helical Geared Motors.....	12
	C.1 Drehstrommotoren – 50 Hz.....	AC Threephase Motors – 50 Hz.....	12
	Einphasen-Wechselstrommotoren – 50 Hz.....	AC Single Phase Motors – 50 Hz.....	12
D	Maßtabellen für BC Stirnradtriebemotoren.....	Dimension Tables for BC Helical Geared Motors..	25
	D.1 Ausführungsarten.....	Designs.....	25
	D.2 2-stufig.....	2-stages.....	26
E	Auswahllisten für BC Stirnradgetriebe.....	Selection Lists for BC Helical Gear Boxes.....	28
	E.1 2-stufig.....	2-stages.....	28
F	Maßtabellen für BC Stirnradgetriebe.....	Dimension Tables for BC Helical Gear Boxes.....	30
	F.1 2-stufig, Typ NF.....	2-stages, Type NF.....	30
	F.2 2-stufig, Typ K.....	2-stages, Type K.....	32
G	Sonderausführungen.....	Special Designs.....	34
	G.1 Flanschausführung ohne Flansch.....	Flange Design without Flange.....	34

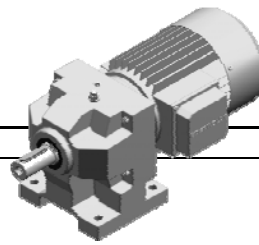

A.2 Einleitung **Introduction**

BOCKWOLDT GETRIEBEMOTORENWERK

BOCKWOLDT bietet Ihnen ein breites Sortiment an Stirnrad-, Flach-, Schnecken-, Kegelrad- und Verstellgetriebemotoren sowie elektronischen Steuerungen.

Als mittelständiges hochflexibles Unternehmen haben wir jahrzehntelange Erfahrung und großes Anwendungs-Know-How als Hersteller von Getrieben und Getriebemotoren, die in sämtlichen Bereichen der industriellen Fertigung und des Maschinen- und Anlagenbaus zum Einsatz kommen. Qualität und deren Sicherung ist hier das Maß aller Dinge. Von der Konstruktion bis zur Montage. Selbst hochwertige Werkstoffe und modernste Fertigungstechniken befreien uns deshalb nicht von der Pflicht ständiger Qualitätskontrollen - von der Warenannahme bis hin zur abschließenden Leistungsprüfung.

Durch Großserien- und Baugruppenfertigung bieten wir Ihnen hochwertige Produkte zu sehr günstigen Preisen an. Ebenso realisieren wir kurzfristig individuelle Lösungen kundenspezifischer Anwendungen.

Schnelle Lieferungen aufgrund großer Teilebevorratung sowie ein Ersatzteil- und Reparaturservice runden unser interessantes Angebot ab.

Qualität macht den Unterschied. Sprechen Sie mit uns über innovative Antriebstechnik.

Produktspektrum

- Stirnradgetriebemotoren
- Flachgetriebemotoren
- Schneckengetriebemotoren
- Kegelradgetriebemotoren
- Verstellgetriebemotoren
- Umrichterintegrierte Getriebemotoren

Inhalt des Kataloges

In diesem Katalog werden BC Stirnradgetriebe und BC Stirnradgetriebemotoren von BOCKWOLDT beschrieben. Es werden Daten zur Antriebsauslegung, Bauformen, technische Daten, Auswahllisten und Maßblätter gezeigt. Weitere Informationen zu Flachgetriebemotoren, Schneckengetriebemotoren, Kegelradgetriebemotoren, Verstellgetriebemotoren und einstufigen Getriebemotoren entnehmen Sie bitte separaten Katalogen.

Kontakt

Bockwoldt GmbH & Co. KG
Sehmsdorfer Str. 43 - 53
D-23843 Bad Oldesloe

Telefon : 04531 89060
Fax : 04531 8906199
E-mail : info@bockwoldt.de
Internet : <http://www.bockwoldt.de>



BOCKWOLDT GEARED MOTORS

BOCKWOLDT has the right solution for your drive requirements, whatever the job. And whether you need Helical-, Shaft-Mounted-, Worm- or Helical-Bevel Geared Motors, Variators or Electronic Control Systems.

Decades of experience and know-how are at our disposal. Our great flexibility as medium-sized manufacturers of Gear Boxes and Geared Motors is appreciated all over the world. Our drives are used in all manufacturing industries, machine building and tero-technology. The universal yardstick here must be quality - guaranteed quality right from the design stage to final assembly. Even high-grade materials and the latest production techniques do not relieve us from a responsibility to enforce continuous quality controls: Constant and repeated controls - from materials acceptance right up until final performance trials. Industrial scale manufacture and componentized construction enable us to provide our high-quality products at very favourable prices. Another important field of our activity is the realization of individual solutions for special applications of our customers.

Short times of delivery resulting from our well-organized stock of component parts, as well as a reliable pre- and after sales service caring for supply of spares and repair work, are the climax of our interesting programme.

Quality makes all the difference. Please contact us for innovative Drive Technology.

The Product Range

- Helical Geared Motors
- Shaft-Mounted Geared Motors
- Worm Geared Motors
- Helical-Bevel Geared Motors
- Variable Speed Geared Motors
- Drive Systems with Integrated Frequency Inverters

Contents of this Catalogue

This catalogue describes BOCKWOLDT BC Helical Gear Boxes and BC Helical Geared Motors. It contains drive selection data, mounting positions, technical data, selection lists and dimension sheets. For more information about Shaft-Mounted Geared Motors, Worm Geared Motors, Helical-Bevel Geared Motors, Variable Speed Geared Motors and One-Stage Helical Geared Motors, please refer to our corresponding separate catalogues.

Contact

Bockwoldt GmbH & Co. KG
Sehmsdorfer Str. 43 - 53
D-23843 Bad Oldesloe

Phone : ++49 4531 89060
Fax : ++49 4531 8906199
E-mail : export@bockwoldt.de
Internet : <http://www.bockwoldt.de>

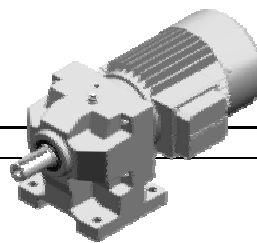

B.2 Typenbezeichnung BC Stirnradgetriebe
Type Designation BC Helical Gear Boxes

Allgemein

Ziffern und Buchstaben legen in der Typenbezeichnung Art, Größe und spezielle Ausführung der BC Stirnradgetriebe und BC Stirnradtriebemotoren fest.

In General

The digits and letters of our type designations determine the kind, size and special design of our BC Helical Gear Boxes and BC Helical Geared Motors.

Beispiel

BOCKWOLDT BC Stirnradtriebemotor, Getriebegröße 125, Fußausführung, 4 poliger Drehstrombremsmotor, Bgr. 71N, schwere Lagerung

Example

BOCKWOLDT BC Helical Geared Motor, gear box size 125, foot-mounting, 4 pole threephase brake motor, frame size 71N, heavy bearings

BC	125	.2	.A	-71N/4D Br	SL
----	-----	----	----	------------	----

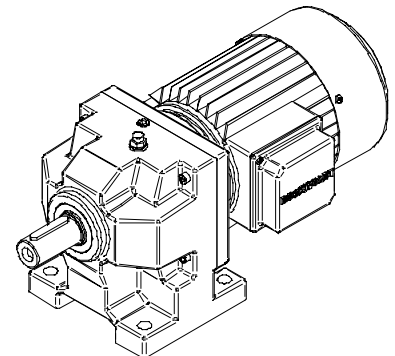

Lagerung	<i>Bearings</i>
SL	: Schwere Lagerung <i>heavy bearings</i>
ohne Bezeichnung	: Normale Lagerung <i>standard bearings</i> <i>without designation</i>

Antrieb	<i>Drive</i>
K	: freie Antriebswelle <i>free input shaft</i>
NF...	: NF 63 ; NF 71 ; NF 80 ; NF 90...usw. <i>NF 63 ; NF 71 ; NF 80 ; NF 90...etc.</i> Normlaterne zum Anbau von IEC-Normmotoren entspr. Baugröße <i>Adaptor suitable for mounting IEC Norm Motors of this motor frame size</i>
-71N/4D Br	: angebauter BOCKWOLDT Werksmotor <i>assembled BOCKWOLDT motor</i> (Typenbezeichnung siehe Seite 5) <i>(for the motor type designation please see page 5)</i>

Gehäuseausführung	<i>Casing</i>
A	: Fußausführung <i>foot-mounting</i>
B	: Flanschausführung <i>flange-mounting</i>
BoF	: Flanschausführung ohne Flansch <i>flange-mounting, without flange</i>
C	: Fuß/Flanschausführung <i>foot/flange-mounting</i>
CoF	: Fuß/Flanschausführung ohne Flansch <i>foot/flange-mounting, without flange</i>
D	: Rührwerksausführung <i>agitator design</i>

Übersetzungsstufen	<i>Stages of ratio</i>
2	: 2 - stufig <i>2 : 2 - stages</i>

Getriebegröße	<i>Gear Box Size</i>
086 , 102 , 125 , 130	: Spitzenhöhe in mm <i>086 , 102 , 125 , 130 : Height of Centers [mm]</i>

BC : BOCKWOLDT Compact

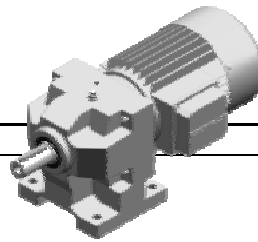

B.3 Typenbezeichnung Motor
Type Designation Motor

Motor

Ausführung nach BOCKWOLDT Werksnorm

Motor

Design acc. to BOCKWOLDT Norm

Beispiel : BOCKWOLDT Motor, Baugröße 71N,
4- polig, Drehstrom mit einer Drehzahl,
Brems

Example : BOCKWOLDT Motor, frame size 71N,
4 poles, AC Threephase Motor with one
output speed, brake

CB 71N /4 D Br

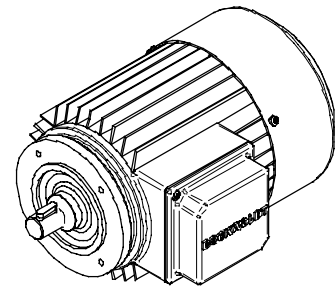

Motorzusatzausrüstungen	Motor Accessories
Br : Bremse	<i>brake</i>
Fl : Fremdlüfteraggregat	<i>separate cooling fan</i>
Ex : Explosionsschutz	<i>explosion-proof execution</i>
oL : ohne Lüfter	<i>without cooling fan</i>
Rü : Rücklaufsperr / Freilauf	<i>backstop / free-wheel running</i>
So : Sonderanpassungen	<i>special execution</i>

Stromart	Kinds of Current
D : Drehstrom mit einer Drehzahl	<i>AC threephase with one output speed</i>
DP : Drehstrom polumschaltbar	<i>AC threephase, pole-changing</i>
E : Einphasenwechselstrom	<i>AC single-phase</i>
G : Gleichstrom	<i>Direct current</i>

Polzahl	Number of Poles
/2 : 2 – polig	<i>2 poles</i>
/4 : 4 – polig	<i>4 poles</i>
/6 : 6 – polig	<i>6 poles</i>
/4/2 : umschaltbar 4/2 – polig	<i>pole-changing 4/2 poles</i>
/6/4 : umschaltbar 6/4 – polig	<i>pole-changing 6/4 poles</i>
/8/2 : umschaltbar 8/2 – polig	<i>pole-changing 8/2 poles</i>

Motorbaugröße	Motor Frame Size
63K 71N 80N 90S 90L 100L 112M	
Spitzenhöhe in mm	<i>Height of Centers [mm]</i>

CB : BOCKWOLDT GmbH & Co. KG

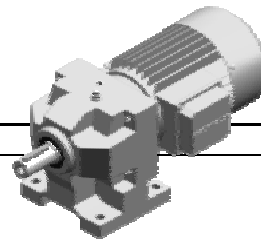

B.4 Betriebsfaktor
Service Factor

Betriebsfaktor

Die Auswirkung der Arbeitsmaschine auf das Getriebe wird durch den Betriebsfaktor f_B berücksichtigt. Dieser wird in Abhängigkeit der täglichen Betriebszeit und der Schalt­häufigkeit ermittelt. Dabei werden je nach Massen­beschleunigungsfaktor drei Stoßgrade unterschieden. Den für Ihre Anwendung zutreffenden Betriebsfaktor f_B können Sie mit nachfolgender Formel unter Berücksichtigung des Belastungsfaktors F_{BI} (Tabelle 11) und Schalthäufigkeits­faktors f_S (Tabelle 12) bestimmen.

Die Betriebsfaktoren der Getriebe sind den Abtriebsdrehzahlen in den Leistungstabellen (Teil C) zugeordnet. Es ist darauf zu achten, daß der Betriebsfaktor des ausgewählten Getriebes mindestens gleich groß oder größer ist als der ermittelte Tabellenwert.

$$f_B = f_{BI} \times f_S$$

Service Factor

The impact of the driving machine onto the Gear Box is shown by the service factor f_B . This service factor depends on the daily operating hours and on the switching frequency. In consideration of the actual mass acceleration factor, three different load classifications are possible. You can determine the service factor f_B related to your application by using the following formula, considering the load factor f_{BI} (see table 11) and the start-stop frequency factor f_S (see table 12). When looking at our selection lists in part C of this catalogue, you will find the service factor of each Geared Motor below the corresponding output speed indication. If this stated service factor is equal to or higher than the service factor you determined acc. to a.m. formula, the chosen type of Geared Motor is suitable for your application.

Tabelle 11 Table 11

Belastungsfaktor f_{BI} Load Factor f_{BI}		Mittlere tägliche Betriebsdauer Average operating hours per day				
Stoßgrad Load Classification	Belastungsart Type of Load	5 h	8 h	12 h	16 h	24 h
		I	Leichter Anlauf, stoßfreier Betrieb, kleine zu beschleunigende Massen. z. B. leichte Transportbänder, Lüfter, Montagebänder, Kreiselpumpen, Kleinaufzüge, Abfüllmaschinen, Rührer und Mischer für Stoffe geringer Viskosität. <i>Easy starting, smooth operation, small masses to be accelerated. e. g. small conveyor belts, ventilators, assembly lines, centrifugal pumps, small elevators, filling machines, stirrers and mixers for materials with low viscosity-gravity constants.</i>	0,8	1,0	1,1
II	Anlauf mit mäßigen Stößen, ungleichmäßiger Betrieb, mittlere zu beschleunigende Massen z. B. Zahnrad- und Rotationspumpen, mittlerer Rührer und Mischer, schwere Transportbänder, Winden, Schiebetore, Schwenkwerke, mittlere Kranfahrzeuge und Drehwerke, Druckmaschinen, Elevatoren. <i>Starting with moderate loads, irregular operating conditions, medium size masses to be accelerated. e. g. gear pumps and rotary pumps, medium size stirrers and mixers, heavy conveyor belts, winches, mechanical gates, crane slewing gears, crane travelling gears, printing machines, vertical bucket conveyors.</i>	1,1	1,2	1,3	1,4	1,6
III	Ungleichmäßiger Betrieb, heftige Stöße, größere zu beschleunigende Massen z. B. Abkantmaschinen, Stanzen, Scheren, Pressen, schwere Mischer, Walzwerke, Zerkleinerungsmaschinen, Zentrifugen, schwere Winden, Aufzüge, große Kranfahrzeuge und Drehwerke, Betonmischer. <i>Irregular operation, heavy loads, larger masses to be accelerated. e. g. press-brakes, punching machines, plateshears, presses, heavy mixers, rollers, crushing mills, centrifuges, heavy winches, elevators, large size crane travelling gears and slewing gears, concrete mixers.</i>	1,4	1,5	1,6	1,7	2,0

Tabelle 12 Table 12

Schalthäufigkeitsfaktor f_S Start-Stop Frequency Factor f_S		Einschaltungen pro Betriebsstunde Starts per Operating Hour		
f_S	Einschaltungen pro Betriebsstunde Starts per Operating Hour			
	≤ 10	11 – 200	> 200	
f_S	1	1,1	1,1 – 1,4	

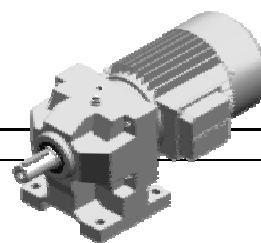

B.5 Radial- und Axialkräfte
Overhung Loads and Thrust Loads

Zulässige Radialkräfte

Die Angaben der zul. Radialkräfte **Fr** in den Leistungstabellen für BC Stirnradgetriebemotoren beziehen sich auf die Mitte des Standard-Abtriebswellenzapfens.

Permissible Overhung Loads

The permissible overhung loads **Fr** indicated in the selection tables for our BC Helical Geared Motors are related to the center of the standard output shaft spigot.

Zulässige Axialkräfte

Liegt keine Radialkraftbelastung vor, ist generell 50% der Radialkraft **Fr** gemäß den Leistungstabellen als Axialkraft (+ = Zug ; - = Druck) einzusetzen. Treten größere Axialkräfte **FA** oder kombinierte Belastungen aus Radialkraft **Fr** und Axialkraft **FA** auf, setzen Sie sich bitte mit uns in Verbindung.

Permissible Thrust Loads

For applications without overhung loads, the permissible thrust load is always 50 % of the radial load value **Fr** acc. to the selection lists (+ = traction ; - = pressure). For operations under bigger thrust loads **FA** or combined loads consisting of overhung load **Fr** and thrust load **FA**, please contact us.

Radialkraftumrechnung bei außermittigem Kraftangriff

Bei Kraftangriff außerhalb der Mitte des Abtriebswellenzapfens müssen die zulässigen Radialkräfte gemäß den nachfolgenden Formeln und Tabellenwerten ermittelt werden. Der kleinere der beiden Werte **Fr_{xw}** (Wellenbelastung) und **Fr_{xl}** (Lagerbelastung) ist der zul. Wert für die Radialkraft **Fr_x** im Abstand "x" vom Abtriebswellenbund.

Conversion of Overhung Loads at Eccentric Impact

For impacts off the output shaft spigot center, the permissible overhung loads need to be determined acc. to the following formulas and tables. Please compare the values for **Fr_{xw}** (shaft load) and **Fr_{xl}** (bearing load). The smaller one of these two values is the permissible overhung load **Fr_x** related to distance "x" from output shaft collar.

Wellenbelastung **Fr_{xw}**
Shaft Load

$$Fr_{xw} = \frac{c}{f + x} [N]$$

Lagerbelastung **Fr_{xl}**
Bearing Load

$$Fr_{xl} = Fr \frac{a}{b + x} [N]$$

Fr = zul. Radialkraft auf Mitte Abtriebswellenzapfen (x=l/2) entsprechend den Leistungstabellen für Stirnradgetriebemotoren.

Fr_{x..} = Kleinster der ermittelten Werte **Fr_{xw}** und **Fr_{xl}** und somit zul. Radialkraft im Abstand "x" vom Wellenbund.

x = Abstand vom Wellenbund bis zum Kraftangriff [mm].

a,b,c = Getriebekonstanten zur Radialkraftumrechnung

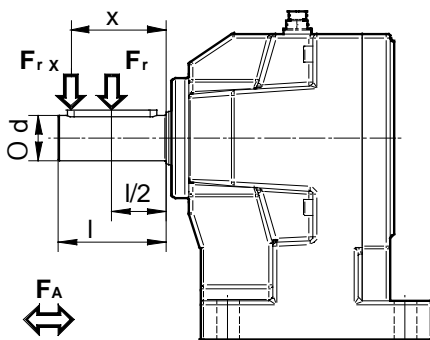

Fr = Permissible overhung load on center of output shaft spigot (x=l/2), acc. to our selection tables for Helical Geared Motors.

Fr_{x..} = Smaller value of **Fr_{xw}** and **Fr_{xl}**, thus permissible overhung load related to distance "x" from output shaft collar.

x = Distance between shaft collar and point of impact [mm].

a,b,c = Gear Box constants for overhung load conversion

Getriebekonstanten zur Radialkraftumrechnung

Gear Box Constants for Overhung Load Conversion

Getriebegröße Gear Box Size [BC]	a [mm]	b [mm]	c [N mm]	f [mm]	ø d x l [mm]
086	81,0	61,0	6,5 x 10 ⁴	10,0	ø 20 x 40
102	91,0	66,0	8,1 x 10 ⁴	0,0	ø 25 x 50
125	113,0	83,0	1,5 x 10 ⁵	0,0	ø 30 x 60
130	140,5	105,5	2,7 x 10 ⁵	0,0	ø 35 x 70

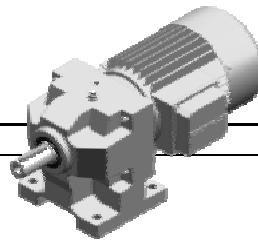

B.6 Einbaulagen
Mounting Positions

Einbaulagen

Die folgende Darstellung zeigt die Lage eines BC Stirnradtriebemotors im Raum.

Mounting Positions

The following drawing illustrates possible mounting positions for our BC Helical Geared Motors.

Fußbauform
Foot-Mounting

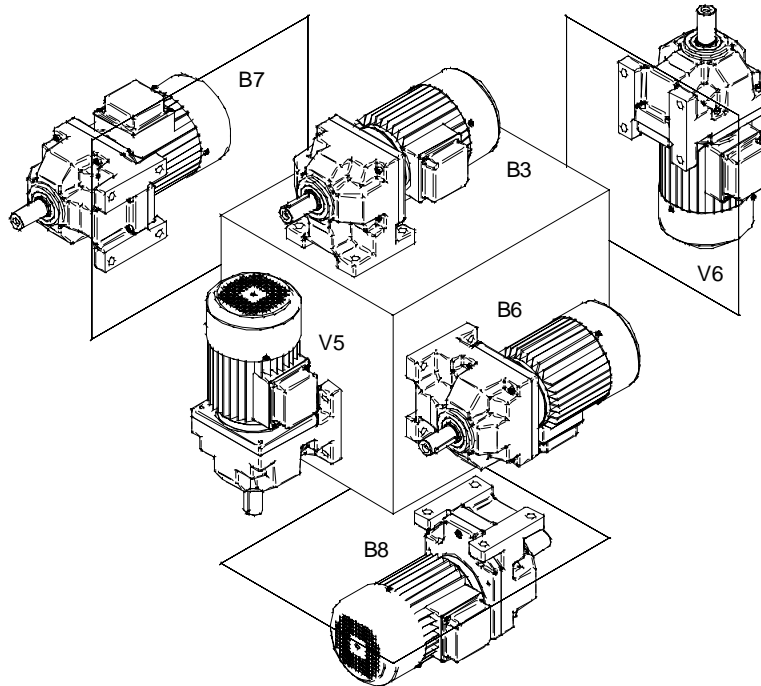

Flanschbauform
Flange-Mounting

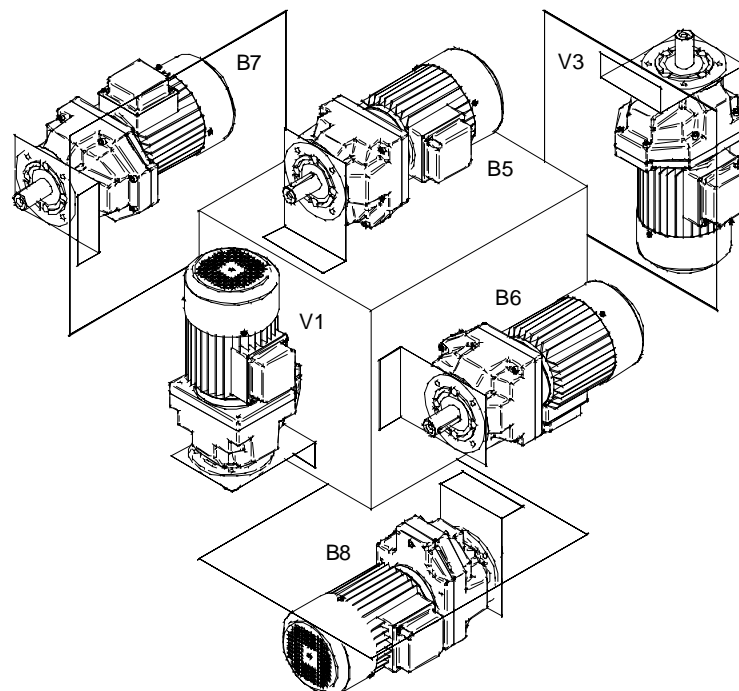

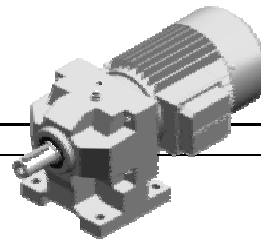

B.7 Position des Klemmenkastens
Terminal Box Position

Position des Klemmenkastens

Die Klemmenkastenordnung für den elektrischen Anschluß Ihres Stirnradgetriebemotors in Übereinstimmung mit Ihren technischen Anforderungen kann gemäß untenstehender Zeichnung gewählt werden. Die gewünschte Position des Klemmenkastens ist durch die Ziffern 1, 2, 3 oder 4 und die Position der Kabeleinführung durch die Buchstaben a oder b eindeutig anzugeben. Falls Ihre Bestellung keine Angaben zur Positionierung des Klemmenkastens enthält, wird der Stirnradgetriebemotor mit Klemmenkasten rechts und Kabeleinführung unten geliefert (Pos. 1a bei Blickrichtung auf den Wellenspiegel des Motors). Die Kabelverschraubung gehört nicht zu unserem Lieferumfang.

Terminal Box Positions

The position of the terminal box can be selected in accordance with your technical requirements, in consideration of the drawing below. The required terminal box position has to be indicated by figure 1, 2, 3 or 4, while the cable inlet position is called either "a" or "b". If we receive your order without detailed specifications concerning the position of the terminal box, your Geared Motors will be supplied with terminal box position right-hand and cable inlet downwards (pos. 1a when looking at the driving shaft of the motor). The cable connectors are not part of our delivery.

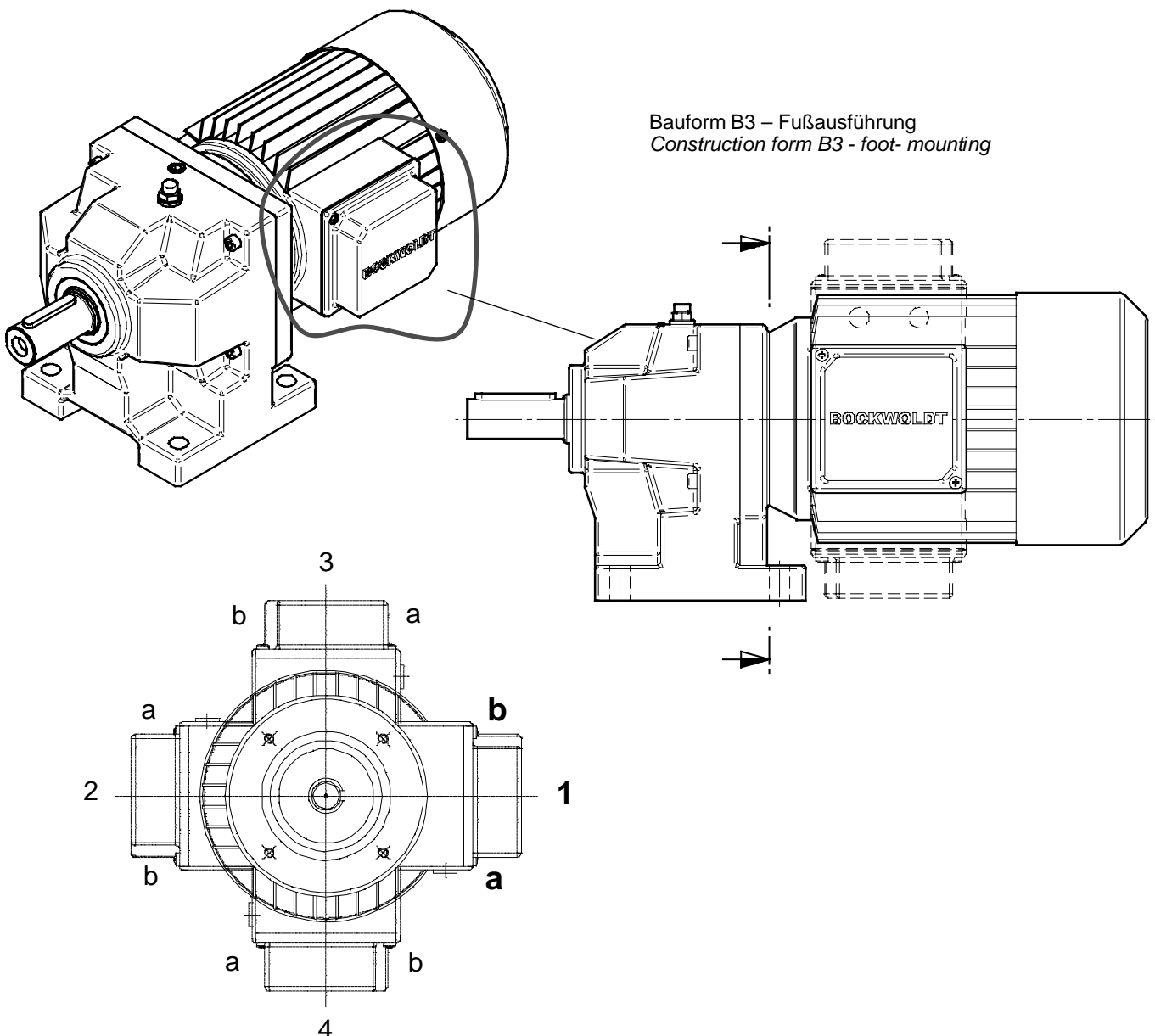

Bauform B3 – Fußausführung
 Construction form B3 - foot-mounting

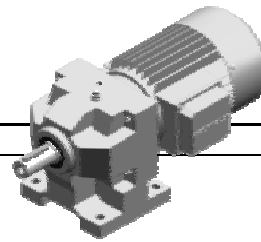

**B.8 Schmierstoffe
Lubricants**

Allgemein

BC Getriebe und Getriebemotoren (außer F-Getriebe) sind bei der Auslieferung betriebsfertig mit Mineralöl entsprechend des standard Umgebungstemperaturbereiches der nachfolgenden Schmierstofftabelle befüllt. Maßgebend hierfür ist die Angabe der Bauform bzw. Einbaulage bei Bestellung des Antriebes. Bei späterer Einbaulagenänderung muß die Schmierstoff-Füllung sowie das Entlüftungsventil und die Verschlußschraube der geänderten Bauform angepasst werden.

In General

Our BC Gear Boxes and Geared Motors (except F-type Gear Boxes) leave our premises filled with their corresponding quantities of mineral oil, acc. to the standard ambient temperature range (table below). The quantity of lubricant needed depends on the requested construction form / mounting position of the drive. If the mounting position is changed later on, the quantity of lubricant as well as the positions of the vent valve and locking screw have to be adapted to the new mounting position accordingly.

Schmierstoffempfehlung für BOCKWOLDT Getriebe

Lubricants for BOCKWOLDT Helical Gear Boxes

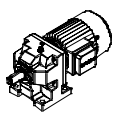
Umgebungstemperaturbereich Ambient Temperature Range (°C)	Schmierstoffart Lubricant		DIN (ISO)	Viskositätsklasse Viscosity Class	ARAL	bp	Castrol	Esso	Mobil	Shell	GIF				
	-50	0										+50	+100		
 BC Stirnradgetriebe BC Helical Gear Box	-10	Standard	+50	Mineralöl Mineral oil	CLP	VG 320	Degol BG 320	Energol GR-XP 320	Alpha SP 320	Falcon CLP 320	Spartan EP 320	Mobilgear 632	Shell Omala 320	Carter EP 320	
	-30		+80	Synthetisches Öl Synthetic oil	CLP PG	VG 220	Degol GS 220	Energol SG-XP 220	Alphasyn PG 220	Polydea PG LP 220	Glycollube 220	Glygoyle 30	Shell Tivela Oil WB	Carter SY 220	
	-40		+80	Synthetisches Öl Synthetic oil	CLP HC	VG 220	Degol PAS 220						Mobil SHC 630	Shell Omala 220 HD	
	-20		+40	biologisch abbaubares Öl Biodegradable oil	E	VG 460	Degol BAB 460								
	-30		+40	Lebensmittel- verträgliches Öl Food-grade oil	HCE	VG 460	Eural Gear 460							Cassida Fluid GL 460	
Wälzlager Bearings	-30		+60	Fett (mineralölbasis) Grease (mineral oil base)			Aralub HL 3	Energrease LS 3	Spheerol AP 3	Glissando 30	Beacon 3	Mobilux 3	Alvania Fett R 3		

Legende : CLP = Mineralöl Mineral oil
 CLP PG = Polyglykol Poly-Glycole
 CLP HC = Synthetische Kohlenwasserstoffe Synthetic Carbon Hydrides
 E = Esteröl (Wassergefährdungsklasse 1) Diester Oil (Water Class of Hazard 1)
 HCE = Synthetische Kohlenwasserstoffe + Esteröl Synthetic Carbon Hydrides + Diester Oil

Achtung ! Das Mischen von mineralischen und synthetischen Schmiermitteln ist nicht zulässig !
 Attention ! Mineral lubricants must not be mixed with synthetic lubricants.

Füllmengen BC Stirnradgetriebe [I]

Lubricant Quantities BC Helical Gear Boxes [I]

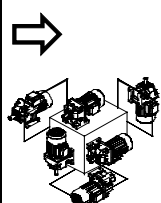
Einbaulagen Mounting Positions	Waagerechte Anordnung Horizontal Position						Senkrechte Anordnung Vertical Position							
	B 3		B 5		B 7		V 1		V 5		V 3		V 6	
	Motor	freie Eingangswelle Input Shaft Extension	Motor	freie Eingangswelle Input Shaft Extension	Motor	freie Eingangswelle Input Shaft Extension	Motor	freie Eingangswelle Input Shaft Extension	Motor	freie Eingangswelle Input Shaft Extension	Motor	freie Eingangswelle Input Shaft Extension	Motor	freie Eingangswelle Input Shaft Extension
 2-stufig 2 stages	086	0,1	0,1	0,2	0,2	0,2	0,2	0,4	0,4	0,4	0,4	0,4	0,4	0,4
	102	0,3	0,3	0,3	0,3	0,3	0,3	0,5	0,5	0,5	0,5	0,5	0,5	0,5
	125	0,4	0,5	0,4	0,5	0,5	0,6	0,7	0,7	0,7	0,7	0,7	0,7	0,7
	130	0,5	0,6	0,5	0,6	0,6	0,7	0,9	0,9	0,9	0,9	0,9	0,9	0,9

○ Entlüftungsventil vent valve
 ● Ablassschraube drain plug
 Die angegebenen Füllmengen sind Richtwerte. In Abhängigkeit der Übersetzung sind geringe Abweichungen möglich.
 The specified quantities are recommended values. The precise values vary depending on gear ratios.

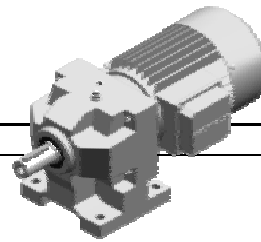

**B.9 ATEX-Checkliste
ATEX Checklist**



Kunde Customer	Firma <i>Company</i>	Straße <i>Address</i>	PLZ/Ort <i>Country</i>
	Ansprechpartner <i>Person to contact</i>	Telefon <i>Telephone Number</i>	Fax / E-Mail

ATEX-Anforderungen für Gerätegruppe II ATEX-Requirements for Device Group II (bitte ankreuzen) (please check off)

Kategorie 1 (besonders hohe Sicherheit) <i>(exceptionally high safety)</i>		Kategorie 2 (hohe Sicherheit) <i>(high safety)</i>		Kategorie 3 (normale Sicherheit) <i>(standard safety)</i>	
Gas (G) Zone 0	Staub Dust (D) Zone 20	Gas (G) Zone 1	Staub Dust (D) Zone 21	Gas (G) Zone 2	Staub Dust (D) Zone 22
<input type="checkbox"/>	<input type="checkbox"/>	<input type="checkbox"/>	<input type="checkbox"/>	<input type="checkbox"/>	<input type="checkbox"/>

**kein Einsatz von Getriebemotoren !
No application of Geared Motors !**

**Temperaturklasse (nur bei Gas)
Temperature class (for gas only)**

- T1 : max. 450°C
 T2 : max. 300°C
 T3 : max. 200°C
 T4 : max. 135°C
 T5 : max. 100°C
 T6 : max. 85°C

**Max. Oberflächentemp. (nur bei Staub)
Max. surface temperature (for dust only)**

..... °C

**Zündschutzart Motor
Type of protection of motor**

- d : druckfeste Kapselung *pressure-tight enclosure*
 n (A) : nicht funkend *not sparking*
 e : erhöhte Sicherheit *increased safety*

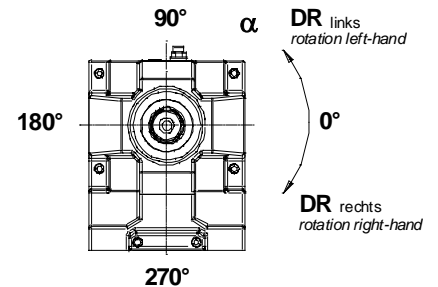
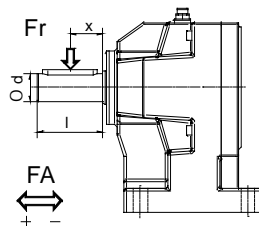
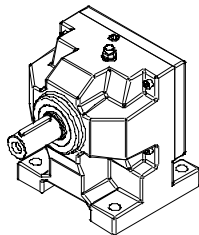

**zus. Daten zur Antriebsauslegung
Additional Data for Drive Selection :**

	Getriebegröße <i>Gear Box Size</i>	Übersetzungsstufen <i>Stages of ratio</i>	Gehäuseausführ. <i>Casing</i>	Antrieb <i>Drive</i>	Lagerung <i>Bearings</i>
Typenbezeichnung..... <i>Type Designation</i>	BC				
Sonstiges..... <i>Additional Details</i>					
Leistung..... <i>Input Power</i> P ₂ [kW]					
Abriebsdrehmoment..... <i>Output Torque</i> M _d [Nm]					
Getriebedrehzahl..... <i>Output Speed</i> n ₂ [min ⁻¹]					
Einbaulage..... <i>Mounting Position</i>					
Spannung..... <i>Voltage</i> U [V]					
Frequenz..... <i>Frequency</i> f [Hz]	(bei Frequenzumrichterbetrieb Frequenzbereich) (for Frequency Inverter Operation please state frequency range)				
vorh. Radialkraft..... <i>Actual Overhung Load</i> F _r [N]					
vorh. Axialkraft..... <i>Actual Thrust Load</i> F _A [N]					
Abm. Abtr.-Welle..... <i>Output Shaft Dim.</i> d x l [mm]					
Kraftangriffspunkt..... <i>Point of Impact</i> X [mm]					
Kraftangriffswinkel..... <i>Angle of Impact</i> α [°]					
Drehrichtung..... <i>Direction of Rotation</i> D _R	<input type="checkbox"/> rechts <i>right-hand</i> <input type="checkbox"/> links <i>left-hand</i>				
Umgebungstemperatur.. <i>Ambient Temperature</i> t _u [°C]					
Aufstellhöhe..... <i>Installation Altitude</i> H [m]					

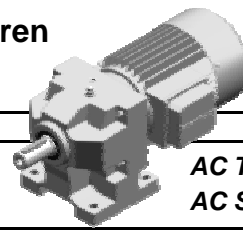

C.2 Drehstrommotoren D - 50 Hz
Einphasen-Wechselstrommotoren E] - 50 Hz

AC Threephase Motors D - 50 Hz
AC Single-Phase Motors [E] - 50 Hz

P	n ₂	i	M _{n2}	f _B	F _r NL	F _r SL	Typ/Type	m	Maß/Dim.
[kW]	[min ⁻¹]		[Nm]		[N]	[N]		[kg]	Seite/Page
0,12	16,4	53,79	67	3,6	2875	4950	BC 125.2 - 63N/6D	21	26
	17,3	51,00	63	1,8	2398	3220	BC 102.2 - 63N/6D	15	26
	17,3	50,82	63	0,9	1907	2180	BC 086.2 - 63N/6D	9	26
	19,2	45,87	57	0,9	1849	2180	BC 086.2 - 63N/6D	9	26
	19,6	45,00	56	2,1	2306	3220	BC 102.2 - 63N/6D	15	26
	21,1	41,68	52	1,0	1796	2180	BC 086.2 - 63N/6D	9	26
	22,0	40,09	50	2,3	2224	3220	BC 102.2 - 63N/6D	15	26
	23,1	38,09	47	1,1	1747	2180	BC 086.2 - 63N/6D	9	26
	24,4	36,00	45	2,5	2150	3220	BC 102.2 - 63N/6D	15	26
	25,2	34,97	43	1,2	1702	2180	BC 086.2 - 63N/6D	9	26
	26,5	51,00	41	2,8	2101	3220	BC 102.2 - 63K/4D [E]	14	26
	26,6	50,82	41	1,3	1680	2180	BC 086.2 - 63K/4D [E]	8	26
	27,3	32,25	40	1,2	1660	2180	BC 086.2 - 63N/6D	9	26
	29,4	45,87	37	1,4	1627	2180	BC 086.2 - 63K/4D [E]	8	26
	30,0	45,00	36	3,2	2019	3220	BC 102.2 - 63K/4D [E]	14	26
	32,4	41,68	34	1,5	1579	2180	BC 086.2 - 63K/4D [E]	8	26
	33,7	40,09	32	3,5	1946	3220	BC 102.2 - 63K/4D [E]	14	26
	35,4	38,09	31	1,7	1535	2180	BC 086.2 - 63K/4D [E]	8	26
	37,5	36,00	29	3,8	1880	3220	BC 102.2 - 63K/4D [E]	14	26
	38,6	34,97	28	1,8	1494	2180	BC 086.2 - 63K/4D [E]	8	26
	41,9	32,25	26	1,9	1456	2180	BC 086.2 - 63K/4D [E]	8	26
	45,2	29,85	24	2,0	1421	2180	BC 086.2 - 63K/4D [E]	8	26
	48,7	27,71	22	2,1	1388	2180	BC 086.2 - 63K/4D [E]	8	26
	52,3	25,80	21	2,3	1356	2180	BC 086.2 - 63K/4D [E]	8	26
	56,1	24,08	19	2,4	1327	2180	BC 086.2 - 63K/4D [E]	8	26
	59,9	22,52	18	2,5	1298	2180	BC 086.2 - 63K/4D [E]	8	26
	64,0	21,11	17	2,6	1271	2180	BC 086.2 - 63K/4D [E]	8	26
	72,0	18,75	15	3,6	1230	2180	BC 086.2 - 63K/4D [E]	8	26
	79,7	16,93	14	3,9	1190	2180	BC 086.2 - 63K/4D [E]	8	26
	87,8	15,38	12	4,2	1154	2180	BC 086.2 - 63K/4D [E]	8	26
	96,0	14,06	11	4,5	1121	2180	BC 086.2 - 63K/4D [E]	8	26
	105	12,91	10	4,8	1090	2180	BC 086.2 - 63K/4D [E]	8	26
	113	11,90	10	5,1	1061	2180	BC 086.2 - 63K/4D [E]	8	26
	123	11,02	9	5,5	1035	2180	BC 086.2 - 63K/4D [E]	8	26
	132	10,23	8	5,8	1010	2180	BC 086.2 - 63K/4D [E]	8	26
	142	9,52	8	6,1	987	2144	BC 086.2 - 63K/4D [E]	8	26
	152	8,89	7	6,4	965	2100	BC 086.2 - 63K/4D [E]	8	26
	162	8,31	7	6,7	944	2058	BC 086.2 - 63K/4D [E]	8	26
	173	7,79	6	7,2	924	2019	BC 086.2 - 63K/4D [E]	8	26
	193	6,98	6	9,6	895	1959	BC 086.2 - 63K/4D [E]	8	26
214	6,30	5	10,4	875	1919	BC 086.2 - 63K/4D [E]	8	26	
236	5,73	5	11,3	858	1884	BC 086.2 - 63K/4D [E]	8	26	
258	5,23	4	12,1	842	1853	BC 086.2 - 63K/4D [E]	8	26	
281	4,81	4	12,9	828	1825	BC 086.2 - 63K/4D [E]	8	26	
305	4,43	4	13,7	816	1799	BC 086.2 - 63K/4D [E]	8	26	
329	4,10	3	14,8	804	1775	BC 086.2 - 63K/4D [E]	8	26	
354	3,81	3	15,6	793	1754	BC 086.2 - 63K/4D [E]	8	26	
380	3,55	3	16,1	784	1735	BC 086.2 - 63K/4D [E]	8	26	
408	3,31	3	16,1	775	1716	BC 086.2 - 63K/4D [E]	8	26	
435	3,10	2	16,0	766	1700	BC 086.2 - 63K/4D [E]	8	26	
466	2,90	2	16,2	758	1683	BC 086.2 - 63K/4D [E]	8	26	
0,18	16,9	53,79	97	2,5	2806	4950	BC 125.2 - 71K/6D	23	26
	17,8	51,00	92	1,3	2320	3220	BC 102.2 - 71K/6D	17	26
	19,2	47,38	85	2,8	2697	4950	BC 125.2 - 71K/6D	23	26
	19,7	46,28	83	4,0	4089	7650	BC 130.2 - 71K/6D	32	26
	20,2	45,00	81	1,4	2235	3220	BC 102.2 - 71K/6D	17	26
	21,6	42,14	76	3,2	2599	4950	BC 125.2 - 71K/6D	23	26
	22,7	40,09	72	1,6	2158	3220	BC 102.2 - 71K/6D	17	26

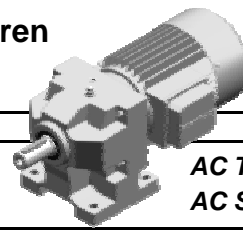

C.2 Drehstrommotoren D - 50 Hz
Einphasen-Wechselstrommotoren E] - 50 Hz

AC Threephase Motors D - 50 Hz
AC Single-Phase Motors [E] - 50 Hz

P	n ₂	i	M _{n2}	f _B	F _{r NL}	F _{r SL}	Typ/Type	m	Maß/Dim.
[kW]	[min ⁻¹]		[Nm]		[N]	[N]		[kg]	Seite/Page
0,18	24,1	37,77	68	3,5	2510	4950	BC 125.2 - 71K/6D	23	26
	25,3	36,00	65	1,7	2089	3220	BC 102.2 - 71K/6D	17	26
	25,3	53,79	65	3,7	2478	4950	BC 125.2 - 63N/4D [E]	20	26
	26,7	51,00	61	1,9	2063	3220	BC 102.2 - 63N/4D [E]	14	26
	26,8	50,82	61	0,9	1636	2180	BC 086.2 - 63N/4D [E]	8	26
	28,2	32,25	58	0,8	1602	2180	BC 086.2 - 71K/6D	11	26
	29,6	45,87	55	1,0	1587	2180	BC 086.2 - 63N/4D [E]	8	26
	30,2	45,00	54	2,1	1985	3220	BC 102.2 - 63N/4D [E]	14	26
	32,6	41,68	50	1,0	1542	2180	BC 086.2 - 63N/4D [E]	8	26
	33,9	40,09	48	2,3	1915	3220	BC 102.2 - 63N/4D [E]	14	26
	35,7	38,09	46	1,1	1501	2180	BC 086.2 - 63N/4D [E]	8	26
	37,8	36,00	43	2,5	1851	3220	BC 102.2 - 63N/4D [E]	14	26
	38,9	34,97	42	1,2	1463	2180	BC 086.2 - 63N/4D [E]	8	26
	41,8	32,54	39	2,8	1793	3220	BC 102.2 - 63N/4D [E]	14	26
	42,2	32,25	39	1,3	1427	2180	BC 086.2 - 63N/4D [E]	8	26
	45,6	29,85	36	1,4	1393	2180	BC 086.2 - 63N/4D [E]	8	26
	46,0	29,57	36	3,0	1740	3220	BC 102.2 - 63N/4D [E]	14	26
	49,1	27,71	33	1,4	1361	2180	BC 086.2 - 63N/4D [E]	8	26
	50,4	27,00	32	3,2	1690	3220	BC 102.2 - 63N/4D [E]	14	26
	52,7	25,80	31	1,5	1331	2180	BC 086.2 - 63N/4D [E]	8	26
	54,9	24,75	30	3,4	1644	3220	BC 102.2 - 63N/4D [E]	14	26
	56,5	24,08	29	1,6	1303	2180	BC 086.2 - 63N/4D [E]	8	26
	59,7	22,76	27	3,6	1600	3220	BC 102.2 - 63N/4D [E]	14	26
	60,4	22,52	27	1,7	1276	2180	BC 086.2 - 63N/4D [E]	8	26
	64,4	21,11	25	1,8	1250	2180	BC 086.2 - 63N/4D [E]	8	26
	64,8	21,00	25	3,8	1559	3220	BC 102.2 - 63N/4D [E]	14	26
	72,5	18,75	23	2,4	1214	2180	BC 086.2 - 63N/4D [E]	8	26
	80,3	16,93	20	2,6	1175	2180	BC 086.2 - 63N/4D [E]	8	26
	88,4	15,38	18	2,8	1140	2180	BC 086.2 - 63N/4D [E]	8	26
	96,7	14,06	17	3,0	1108	2180	BC 086.2 - 63N/4D [E]	8	26
	105	12,91	16	3,2	1078	2180	BC 086.2 - 63N/4D [E]	8	26
	114	11,90	14	3,4	1050	2180	BC 086.2 - 63N/4D [E]	8	26
	123	11,02	13	3,7	1025	2180	BC 086.2 - 63N/4D [E]	8	26
	133	10,23	12	3,9	1000	2180	BC 086.2 - 63N/4D [E]	8	26
	143	9,52	11	4,1	977	2134	BC 086.2 - 63N/4D [E]	8	26
	153	8,89	11	4,3	956	2091	BC 086.2 - 63N/4D [E]	8	26
	164	8,31	10	4,5	935	2049	BC 086.2 - 63N/4D [E]	8	26
	175	7,79	9	4,8	916	2010	BC 086.2 - 63N/4D [E]	8	26
	195	6,98	8	6,4	889	1953	BC 086.2 - 63N/4D [E]	8	26
	216	6,30	8	7,0	870	1914	BC 086.2 - 63N/4D [E]	8	26
237	5,73	7	7,6	853	1879	BC 086.2 - 63N/4D [E]	8	26	
260	5,23	6	8,1	838	1848	BC 086.2 - 63N/4D [E]	8	26	
283	4,81	6	8,7	824	1820	BC 086.2 - 63N/4D [E]	8	26	
307	4,43	5	9,2	811	1794	BC 086.2 - 63N/4D [E]	8	26	
332	4,10	5	10,0	800	1771	BC 086.2 - 63N/4D [E]	8	26	
357	3,81	5	10,5	790	1750	BC 086.2 - 63N/4D [E]	8	26	
383	3,55	4	10,8	780	1731	BC 086.2 - 63N/4D [E]	8	26	
411	3,31	4	10,8	771	1713	BC 086.2 - 63N/4D [E]	8	26	
439	3,10	4	10,7	763	1696	BC 086.2 - 63N/4D [E]	8	26	
469	2,90	3	10,9	755	1680	BC 086.2 - 63N/4D [E]	8	26	
482	5,73	3	15,3	753	1675	BC 086.2 - 63K/2D	8	26	
528	5,23	3	16,5	743	1654	BC 086.2 - 63K/2D	8	26	
574	4,81	3	17,6	735	1637	BC 086.2 - 63K/2D	8	26	
623	4,43	3	18,7	727	1620	BC 086.2 - 63K/2D	8	26	
673	4,10	2	20,2	720	1606	BC 086.2 - 63K/2D	8	26	
724	3,81	2	21,3	713	1593	BC 086.2 - 63K/2D	8	26	
777	3,55	2	21,9	707	1581	BC 086.2 - 63K/2D	8	26	
834	3,31	2	22,0	702	1570	BC 086.2 - 63K/2D	8	26	
890	3,10	2	21,8	697	1560	BC 086.2 - 63K/2D	8	26	
952	2,90	2	22,1	693	1550	BC 086.2 - 63K/2D	8	26	

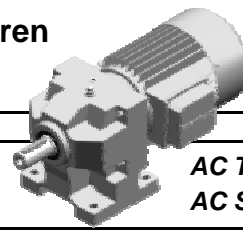

C.2 Drehstrommotoren D - 50 Hz
Einphasen-Wechselstrommotoren E] - 50 Hz

AC Threephase Motors D - 50 Hz
AC Single-Phase Motors [E] - 50 Hz

P	n ₂	i	M _{n2}	f _B	F _{r NL}	F _{r SL}	Typ/Type	m	Maß/Dim.
[kW]	[min ⁻¹]		[Nm]		[N]	[N]		[kg]	Seite/Page
0,25	17,1	53,79	133	1,8	2748	4950	BC 125.2 - 71N/6D	25	26
	18,0	51,00	126	0,9	2245	3220	BC 102.2 - 71N/6D	19	26
	19,4	47,38	117	2,1	2645	4950	BC 125.2 - 71N/6D	25	26
	19,9	46,28	114	2,9	4042	7650	BC 130.2 - 71N/6D	34	26
	20,4	45,00	111	1,0	2168	3220	BC 102.2 - 71N/6D	19	26
	21,8	42,14	104	2,3	2551	4950	BC 125.2 - 71N/6D	25	26
	22,3	41,21	102	3,2	3895	7650	BC 130.2 - 71N/6D	34	26
	22,9	40,09	99	1,1	2098	3220	BC 102.2 - 71N/6D	19	26
	24,4	37,77	93	2,6	2467	4950	BC 125.2 - 71N/6D	25	26
	24,9	36,99	91	3,5	3762	7650	BC 130.2 - 71N/6D	34	26
	25,5	53,79	89	2,7	2442	4950	BC 125.2 - 71K/4D [E]	22	26
	25,6	36,00	89	1,2	2033	3220	BC 102.2 - 71N/6D	19	26
	26,9	51,00	84	1,4	2016	3220	BC 102.2 - 71K/4D [E]	16	26
	27,5	33,42	82	3,8	3641	7650	BC 130.2 - 71N/6D	34	26
	28,9	47,38	78	3,1	2347	4950	BC 125.2 - 71K/4D [E]	22	26
	30,4	45,00	75	1,5	1943	3220	BC 102.2 - 71K/4D [E]	16	26
	32,5	42,14	70	3,4	2263	4950	BC 125.2 - 71K/4D [E]	22	26
	34,2	40,09	66	1,7	1877	3220	BC 102.2 - 71K/4D [E]	16	26
	36,0	38,09	63	0,8	1459	2180	BC 086.2 - 71K/4D [E]	10	26
	36,3	37,77	63	3,8	2186	4950	BC 125.2 - 71K/4D [E]	22	26
	38,1	36,00	60	1,8	1816	3220	BC 102.2 - 71K/4D [E]	16	26
	39,2	34,97	58	0,9	1424	2180	BC 086.2 - 71K/4D [E]	10	26
	42,1	32,54	54	2,0	1761	3220	BC 102.2 - 71K/4D [E]	16	26
	42,5	32,25	53	0,9	1391	2180	BC 086.2 - 71K/4D [E]	10	26
	45,9	29,85	49	1,0	1359	2180	BC 086.2 - 71K/4D [E]	10	26
	46,3	29,57	49	2,1	1710	3220	BC 102.2 - 71K/4D [E]	16	26
	49,4	27,71	46	1,0	1330	2180	BC 086.2 - 71K/4D [E]	10	26
	50,7	27,00	45	2,3	1662	3220	BC 102.2 - 71K/4D [E]	16	26
	53,1	25,80	43	1,1	1301	2180	BC 086.2 - 71K/4D [E]	10	26
	55,4	24,75	41	2,5	1618	3220	BC 102.2 - 71K/4D [E]	16	26
	56,9	24,08	40	1,2	1275	2180	BC 086.2 - 71K/4D [E]	10	26
	60,2	22,76	38	2,6	1576	3220	BC 102.2 - 71K/4D [E]	16	26
	60,8	22,52	37	1,2	1249	2180	BC 086.2 - 71K/4D [E]	10	26
	64,9	21,11	35	1,3	1224	2180	BC 086.2 - 71K/4D [E]	10	26
	65,2	21,00	35	2,8	1536	3220	BC 102.2 - 71K/4D [E]	16	26
	69,4	19,73	33	3,4	1516	3220	BC 102.2 - 71K/4D [E]	16	26
	73,1	18,75	31	1,7	1195	2180	BC 086.2 - 71K/4D [E]	10	26
	76,8	17,84	30	3,7	1468	3220	BC 102.2 - 71K/4D [E]	16	26
	80,9	16,93	28	1,9	1158	2180	BC 086.2 - 71K/4D [E]	10	26
	84,5	16,21	27	3,9	1424	3220	BC 102.2 - 71K/4D [E]	16	26
	89,1	15,38	25	2,0	1124	2180	BC 086.2 - 71K/4D [E]	10	26
	97,4	14,06	23	2,2	1093	2180	BC 086.2 - 71K/4D [E]	10	26
	106	12,91	21	2,3	1064	2180	BC 086.2 - 71K/4D [E]	10	26
	115	11,90	20	2,5	1037	2180	BC 086.2 - 71K/4D [E]	10	26
124	11,02	18	2,7	1012	2180	BC 086.2 - 71K/4D [E]	10	26	
134	10,23	17	2,8	989	2169	BC 086.2 - 71K/4D [E]	10	26	
144	9,52	16	3,0	966	2124	BC 086.2 - 71K/4D [E]	10	26	
154	8,89	15	3,1	945	2081	BC 086.2 - 71K/4D [E]	10	26	
165	8,31	14	3,3	925	2040	BC 086.2 - 71K/4D [E]	10	26	
176	7,79	13	3,5	906	2001	BC 086.2 - 71K/4D [E]	10	26	
196	6,98	12	4,7	882	1946	BC 086.2 - 71K/4D [E]	10	26	
217	6,30	10	5,1	864	1908	BC 086.2 - 71K/4D [E]	10	26	
239	5,73	9	5,5	847	1873	BC 086.2 - 71K/4D [E]	10	26	
262	5,23	9	5,9	832	1842	BC 086.2 - 71K/4D [E]	10	26	
285	4,81	8	6,3	819	1815	BC 086.2 - 71K/4D [E]	10	26	
309	4,43	7	6,7	807	1790	BC 086.2 - 71K/4D [E]	10	26	
334	4,10	7	7,2	796	1767	BC 086.2 - 71K/4D [E]	10	26	
360	3,81	6	7,6	785	1746	BC 086.2 - 71K/4D [E]	10	26	
386	3,55	6	7,8	776	1727	BC 086.2 - 71K/4D [E]	10	26	
414	3,31	5	7,8	767	1709	BC 086.2 - 71K/4D [E]	10	26	

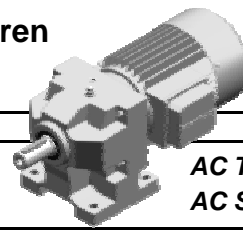

C.2 Drehstrommotoren D - 50 Hz
Einphasen-Wechselstrommotoren E] - 50 Hz

AC Threephase Motors D - 50 Hz
AC Single-Phase Motors [E] - 50 Hz

P [kW]	n₂ [min ⁻¹]	i	M_{n2} [Nm]	f_B	F_{r NL} [N]	F_{r SL} [N]	Typ/Type	m [kg]	Maß/Dim. Seite/Page
0,25	442	3,10	5	7,8	760	1692	BC 086.2 - 71K/4D [E]	10	26
	472	2,90	5	7,9	752	1677	BC 086.2 - 71K/4D [E]	10	26
	483	5,73	5	11,1	751	1672	BC 086.2 - 63N/2D	9	26
	530	5,23	4	11,9	741	1652	BC 086.2 - 63N/2D	9	26
	576	4,81	4	12,7	733	1635	BC 086.2 - 63N/2D	9	26
	625	4,43	4	13,5	725	1618	BC 086.2 - 63N/2D	9	26
	676	4,10	3	14,6	718	1604	BC 086.2 - 63N/2D	9	26
	727	3,81	3	15,4	711	1591	BC 086.2 - 63N/2D	9	26
	780	3,55	3	15,8	706	1579	BC 086.2 - 63N/2D	9	26
	837	3,31	3	15,9	700	1568	BC 086.2 - 63N/2D	9	26
	894	3,10	3	15,8	696	1558	BC 086.2 - 63N/2D	9	26
	955	2,90	2	16,0	691	1549	BC 086.2 - 63N/2D	9	26
	0,37	17,1	53,79	196	1,2	2657	4950	BC 125.2 - 80K/6D	26
19,4		47,38	173	1,4	2564	4950	BC 125.2 - 80K/6D	26	26
19,9		46,28	169	2,0	3982	7650	BC 130.2 - 80K/6D	35	26
21,8		42,14	154	1,6	2480	4950	BC 125.2 - 80K/6D	26	26
22,3		41,21	150	2,2	3841	7650	BC 130.2 - 80K/6D	35	26
24,4		37,77	138	1,7	2402	4950	BC 125.2 - 80K/6D	26	26
24,9		36,99	135	2,3	3713	7650	BC 130.2 - 80K/6D	35	26
25,6		36,00	131	0,8	1940	3220	BC 102.2 - 80K/6D	20	26
25,7		53,79	131	1,8	2380	4950	BC 125.2 - 71N/4D [E]	23	26
27,1		51,00	124	0,9	1932	3220	BC 102.2 - 71N/4D [E]	17	26
27,5		33,42	122	2,5	3596	7650	BC 130.2 - 80K/6D	35	26
29,1		47,38	115	2,1	2292	4950	BC 125.2 - 71N/4D [E]	23	26
29,8		46,28	113	2,9	3517	7650	BC 130.2 - 71N/4D [E]	32	26
30,1		30,53	111	3,0	3506	7650	BC 130.2 - 80K/6D	35	26
30,7		45,00	109	1,1	1868	3220	BC 102.2 - 71N/4D [E]	17	26
32,8		42,14	102	2,3	2213	4950	BC 125.2 - 71N/4D [E]	23	26
33,5		41,21	100	3,2	3390	7650	BC 130.2 - 71N/4D [E]	32	26
34,4		40,09	98	1,1	1810	3220	BC 102.2 - 71N/4D [E]	17	26
36,5		37,77	92	2,6	2140	4950	BC 125.2 - 71N/4D [E]	23	26
37,3		36,99	90	3,5	3275	7650	BC 130.2 - 71N/4D [E]	32	26
38,3		36,00	88	1,3	1756	3220	BC 102.2 - 71N/4D [E]	17	26
40,5		34,07	83	2,8	2073	4857	BC 125.2 - 71N/4D [E]	23	26
41,3		33,42	81	3,8	3170	7650	BC 130.2 - 71N/4D [E]	32	26
42,4		32,54	79	1,4	1705	3220	BC 102.2 - 71N/4D [E]	17	26
44,7		30,90	75	3,0	2012	4720	BC 125.2 - 71N/4D [E]	23	26
46,7		29,57	72	1,5	1659	3220	BC 102.2 - 71N/4D [E]	17	26
49,0		28,15	68	3,3	1954	4593	BC 125.2 - 71N/4D [E]	23	26
51,1		27,00	66	1,6	1615	3220	BC 102.2 - 71N/4D [E]	17	26
51,6		26,73	65	3,7	1933	4530	BC 125.2 - 71N/4D [E]	23	26
55,8		24,75	60	1,7	1573	3220	BC 102.2 - 71N/4D [E]	17	26
60,6		22,76	55	1,8	1534	3220	BC 102.2 - 71N/4D [E]	17	26
61,3		22,52	55	0,8	1201	2180	BC 086.2 - 71N/4D [E]	11	26
65,4		21,11	51	0,9	1179	2180	BC 086.2 - 71N/4D [E]	11	26
65,7		21,00	51	1,9	1497	3220	BC 102.2 - 71N/4D [E]	17	26
69,9		19,73	48	2,3	1484	3220	BC 102.2 - 71N/4D [E]	17	26
73,6		18,75	46	1,2	1163	2180	BC 086.2 - 71N/4D [E]	11	26
77,4		17,84	43	2,5	1439	3220	BC 102.2 - 71N/4D [E]	17	26
81,5		16,93	41	1,3	1129	2180	BC 086.2 - 71N/4D [E]	11	26
85,1		16,21	39	2,7	1397	3220	BC 102.2 - 71N/4D [E]	17	26
89,7		15,38	37	1,4	1097	2180	BC 086.2 - 71N/4D [E]	11	26
93,2		14,80	36	2,9	1358	3220	BC 102.2 - 71N/4D [E]	17	26
98,2		14,06	34	1,5	1068	2180	BC 086.2 - 71N/4D [E]	11	26
102	13,57	33	3,1	1322	3156	BC 102.2 - 71N/4D [E]	17	26	
107	12,91	31	1,6	1041	2180	BC 086.2 - 71N/4D [E]	11	26	
108	12,80	31	3,7	1306	3108	BC 102.2 - 71N/4D [E]	17	26	
116	11,90	29	1,7	1016	2180	BC 086.2 - 71N/4D [E]	11	26	

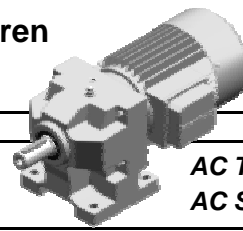

C.2 Drehstrommotoren D - 50 Hz
Einphasen-Wechselstrommotoren E] - 50 Hz

AC Threephase Motors D - 50 Hz
AC Single-Phase Motors [E] - 50 Hz

P	n ₂	i	M _{n2}	f _B	F _{r NL}	F _{r SL}	Typ/Type	m	Maß/Dim.
[kW]	[min ⁻¹]		[Nm]		[N]	[N]		[kg]	Seite/Page
0,37	125	11,02	27	1,8	992	2180	BC 086.2 - 71N/4D [E]	11	26
	135	10,23	25	1,9	969	2154	BC 086.2 - 71N/4D [E]	11	26
	145	9,52	23	2,0	948	2109	BC 086.2 - 71N/4D [E]	11	26
	155	8,89	22	2,1	928	2067	BC 086.2 - 71N/4D [E]	11	26
	166	8,31	20	2,2	909	2026	BC 086.2 - 71N/4D [E]	11	26
	177	7,79	19	2,4	890	1988	BC 086.2 - 71N/4D [E]	11	26
	198	6,98	17	3,2	871	1937	BC 086.2 - 71N/4D [E]	11	26
	219	6,30	15	3,5	854	1899	BC 086.2 - 71N/4D [E]	11	26
	241	5,73	14	3,7	838	1866	BC 086.2 - 71N/4D [E]	11	26
	264	5,23	13	4,0	824	1835	BC 086.2 - 71N/4D [E]	11	26
	287	4,81	12	4,3	811	1808	BC 086.2 - 71N/4D [E]	11	26
	312	4,43	11	4,5	799	1783	BC 086.2 - 71N/4D [E]	11	26
	337	4,10	10	4,9	789	1761	BC 086.2 - 71N/4D [E]	11	26
	362	3,81	9	5,2	779	1740	BC 086.2 - 71N/4D [E]	11	26
	389	3,55	9	5,3	770	1721	BC 086.2 - 71N/4D [E]	11	26
	417	3,31	8	5,3	762	1703	BC 086.2 - 71N/4D [E]	11	26
	445	3,10	8	5,3	754	1687	BC 086.2 - 71N/4D [E]	11	26
	476	2,90	7	5,4	747	1672	BC 086.2 - 71N/4D [E]	11	26
	485	5,73	7	7,5	747	1669	BC 086.2 - 71K/2D	10	26
	532	5,23	6	8,1	737	1649	BC 086.2 - 71K/2D	10	26
	578	4,81	6	8,6	729	1632	BC 086.2 - 71K/2D	10	26
	628	4,43	5	9,2	721	1616	BC 086.2 - 71K/2D	10	26
	678	4,10	5	9,9	715	1601	BC 086.2 - 71K/2D	10	26
	730	3,81	5	10,4	708	1589	BC 086.2 - 71K/2D	10	26
	783	3,55	4	10,7	703	1577	BC 086.2 - 71K/2D	10	26
	840	3,31	4	10,8	698	1566	BC 086.2 - 71K/2D	10	26
897	3,10	4	10,7	693	1556	BC 086.2 - 71K/2D	10	26	
959	2,90	4	10,9	689	1547	BC 086.2 - 71K/2D	10	26	
0,55	16,9	53,79	295	0,8	2507	4950	BC 125.2 - 80N/6D	27	26
	19,2	47,38	260	0,9	2433	4950	BC 125.2 - 80N/6D	27	26
	19,7	46,28	254	1,3	3897	7650	BC 130.2 - 80N/6D	36	26
	21,6	42,14	231	1,0	2364	4950	BC 125.2 - 80N/6D	27	26
	22,1	41,21	226	1,4	3766	7650	BC 130.2 - 80N/6D	36	26
	24,1	37,77	207	1,2	2298	4950	BC 125.2 - 80N/6D	27	26
	24,6	36,99	203	1,6	3646	7650	BC 130.2 - 80N/6D	36	26
	25,7	53,79	194	1,2	2286	4950	BC 125.2 - 80K/4D [E]	25	26
	27,2	33,42	183	1,7	3536	7650	BC 130.2 - 80N/6D	36	26
	29,1	47,38	171	1,4	2209	4950	BC 125.2 - 80K/4D [E]	25	26
	29,8	46,28	167	2,0	3456	7650	BC 130.2 - 80K/4D [E]	34	26
	32,8	42,14	152	1,6	2138	4950	BC 125.2 - 80K/4D [E]	25	26
	33,5	41,21	149	2,2	3335	7650	BC 130.2 - 80K/4D [E]	34	26
	36,5	37,77	137	1,8	2073	4950	BC 125.2 - 80K/4D [E]	25	26
	37,3	36,99	134	2,4	3226	7650	BC 130.2 - 80K/4D [E]	34	26
	38,3	36,00	130	0,8	1658	3220	BC 102.2 - 80K/4D [E]	19	26
	40,5	34,07	123	1,9	2012	4818	BC 125.2 - 80K/4D [E]	25	26
	41,3	33,42	121	2,6	3125	7650	BC 130.2 - 80K/4D [E]	34	26
	42,4	32,54	118	0,9	1617	3220	BC 102.2 - 80K/4D [E]	19	26
	44,7	30,90	112	2,0	1955	4684	BC 125.2 - 80K/4D [E]	25	26
	45,2	30,53	110	3,0	3048	7650	BC 130.2 - 80K/4D [E]	34	26
	46,7	29,57	107	1,0	1578	3220	BC 102.2 - 80K/4D [E]	19	26
	49,0	28,15	102	2,2	1902	4560	BC 125.2 - 80K/4D [E]	25	26
	50,8	27,19	98	3,3	2939	7650	BC 130.2 - 80K/4D [E]	34	26
	51,1	27,00	98	1,1	1540	3220	BC 102.2 - 80K/4D [E]	19	26
	51,6	26,73	97	2,5	1889	4501	BC 125.2 - 80K/4D [E]	25	26
	55,8	24,75	89	1,1	1505	3220	BC 102.2 - 80K/4D [E]	19	26
	56,5	24,40	88	3,6	2840	7425	BC 130.2 - 80K/4D [E]	34	26
	57,6	23,96	87	2,8	1828	4360	BC 125.2 - 80K/4D [E]	25	26
	60,6	22,76	82	1,2	1470	3220	BC 102.2 - 80K/4D [E]	19	26
	62,6	22,05	80	3,9	2750	7206	BC 130.2 - 80K/4D [E]	34	26

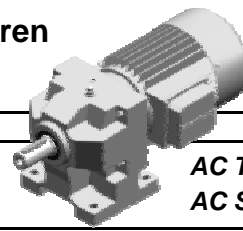

C.2 Drehstrommotoren D - 50 Hz
Einphasen-Wechselstrommotoren E] - 50 Hz

AC Threephase Motors D - 50 Hz
AC Single-Phase Motors [E] - 50 Hz

P	n ₂	i	M _{n2}	f _B	F _{r NL}	F _{r SL}	Typ/Type	m	Maß/Dim.
[kW]	[min ⁻¹]		[Nm]		[N]	[N]		[kg]	Seite/Page
0,55	63,9	21,61	78	3,0	1771	4231	BC 125.2 - 80K/4D [E]	25	26
	65,7	21,00	76	1,3	1437	3220	BC 102.2 - 80K/4D [E]	19	26
	69,9	19,73	71	1,5	1437	3220	BC 102.2 - 80K/4D [E]	19	26
	70,4	19,60	71	3,2	1719	4112	BC 125.2 - 80K/4D [E]	25	26
	75,1	18,38	66	3,6	1697	4044	BC 125.2 - 80K/4D [E]	25	26
	77,4	17,84	64	1,7	1396	3220	BC 102.2 - 80K/4D [E]	19	26
	81,5	16,93	61	0,9	1084	2180	BC 086.2 - 80K/4D [E]	13	26
	85,1	16,21	59	1,8	1358	3220	BC 102.2 - 80K/4D [E]	19	26
	89,7	15,38	56	0,9	1057	2180	BC 086.2 - 80K/4D [E]	13	26
	93,2	14,80	54	1,9	1322	3215	BC 102.2 - 80K/4D [E]	19	26
	98,2	14,06	51	1,0	1031	2180	BC 086.2 - 80K/4D [E]	13	26
	102	13,57	49	2,1	1288	3135	BC 102.2 - 80K/4D [E]	19	26
	107	12,91	47	1,1	1007	2180	BC 086.2 - 80K/4D [E]	13	26
	108	12,80	46	2,5	1279	3091	BC 102.2 - 80K/4D [E]	19	26
	116	11,90	43	1,1	984	2180	BC 086.2 - 80K/4D [E]	13	26
	121	11,40	41	2,7	1235	2988	BC 102.2 - 80K/4D [E]	19	26
	125	11,02	40	1,2	962	2180	BC 086.2 - 80K/4D [E]	13	26
	135	10,24	37	3,0	1196	2896	BC 102.2 - 80K/4D [E]	19	26
	135	10,23	37	1,3	942	2137	BC 086.2 - 80K/4D [E]	13	26
	145	9,52	34	1,4	922	2093	BC 086.2 - 80K/4D [E]	13	26
	149	9,26	33	3,2	1159	2812	BC 102.2 - 80K/4D [E]	19	26
	155	8,89	32	1,4	903	2052	BC 086.2 - 80K/4D [E]	13	26
	164	8,41	30	3,5	1125	2734	BC 102.2 - 80K/4D [E]	19	26
	166	8,31	30	1,5	885	2012	BC 086.2 - 80K/4D [E]	13	26
	177	7,79	28	1,6	868	1975	BC 086.2 - 80K/4D [E]	13	26
	180	7,68	28	3,7	1094	2662	BC 102.2 - 80K/4D [E]	19	26
	196	7,04	25	4,0	1064	2594	BC 102.2 - 80K/4D [E]	19	26
	198	6,98	25	2,1	856	1927	BC 086.2 - 80K/4D [E]	13	26
	219	6,30	23	2,3	840	1890	BC 086.2 - 80K/4D [E]	13	26
	241	5,73	21	2,5	825	1857	BC 086.2 - 80K/4D [E]	13	26
	264	5,23	19	2,7	812	1827	BC 086.2 - 80K/4D [E]	13	26
	287	4,81	17	2,9	800	1801	BC 086.2 - 80K/4D [E]	13	26
	312	4,43	16	3,1	789	1777	BC 086.2 - 80K/4D [E]	13	26
	337	4,10	15	3,3	779	1754	BC 086.2 - 80K/4D [E]	13	26
362	3,81	14	3,5	770	1734	BC 086.2 - 80K/4D [E]	13	26	
389	3,55	13	3,6	762	1716	BC 086.2 - 80K/4D [E]	13	26	
417	3,31	12	3,6	754	1698	BC 086.2 - 80K/4D [E]	13	26	
445	3,10	11	3,6	746	1683	BC 086.2 - 80K/4D [E]	13	26	
476	2,90	10	3,6	740	1667	BC 086.2 - 80K/4D [E]	13	26	
487	5,73	10	5,1	740	1664	BC 086.2 - 71N/2D	11	26	
533	5,23	9	5,5	731	1645	BC 086.2 - 71N/2D	11	26	
580	4,81	9	5,8	724	1628	BC 086.2 - 71N/2D	11	26	
630	4,43	8	6,2	716	1612	BC 086.2 - 71N/2D	11	26	
680	4,10	7	6,7	710	1598	BC 086.2 - 71N/2D	11	26	
732	3,81	7	7,0	704	1585	BC 086.2 - 71N/2D	11	26	
786	3,55	6	7,2	699	1574	BC 086.2 - 71N/2D	11	26	
843	3,31	6	7,3	694	1563	BC 086.2 - 71N/2D	11	26	
900	3,10	6	7,2	689	1553	BC 086.2 - 71N/2D	11	26	
962	2,90	5	7,3	685	1544	BC 086.2 - 71N/2D	11	26	
0,75	19,9	46,28	342	1,0	3768	7650	BC 130.2 - 90S/6D	39	26
	22,3	41,21	305	1,1	3649	7650	BC 130.2 - 90S/6D	39	26
	24,4	37,77	279	0,9	2153	4950	BC 125.2 - 90S/6D	30	26
	24,9	36,99	274	1,2	3540	7650	BC 130.2 - 90S/6D	39	26
	25,8	53,79	263	0,9	2164	4950	BC 125.2 - 80N/4D [E]	26	26
	27,5	33,42	247	1,3	3438	7650	BC 130.2 - 90S/6D	39	26
	29,3	47,38	232	1,0	2102	4950	BC 125.2 - 80N/4D [E]	26	26
	30,0	46,28	227	1,5	3377	7650	BC 130.2 - 80N/4D [E]	35	26
	33,0	42,14	206	1,2	2042	4950	BC 125.2 - 80N/4D [E]	26	26

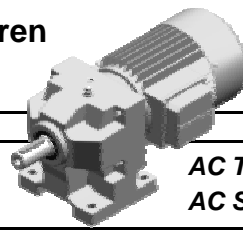

C.2 Drehstrommotoren D - 50 Hz
Einphasen-Wechselstrommotoren E] - 50 Hz

AC Threephase Motors D - 50 Hz
AC Single-Phase Motors [E] - 50 Hz

P	n ₂	i	M _{n2}	f _B	F _{r NL}	F _{r SL}	Typ/Type	m	Maß/Dim.
[kW]	[min ⁻¹]		[Nm]		[N]	[N]		[kg]	Seite/Page
0,75	33,7	41,21	202	1,6	3263	7650	BC 130.2 - 80N/4D [E]	35	26
	36,8	37,77	185	1,3	1986	4905	BC 125.2 - 80N/4D [E]	26	26
	37,6	36,99	181	1,7	3160	7650	BC 130.2 - 80N/4D [E]	35	26
	40,8	34,07	167	1,4	1933	4764	BC 125.2 - 80N/4D [E]	26	26
	41,6	33,42	164	1,9	3065	7650	BC 130.2 - 80N/4D [E]	35	26
	45,0	30,90	151	1,5	1883	4634	BC 125.2 - 80N/4D [E]	26	26
	45,5	30,53	149	2,2	2997	7650	BC 130.2 - 80N/4D [E]	35	26
	49,4	28,15	138	1,6	1835	4512	BC 125.2 - 80N/4D [E]	26	26
	51,1	27,19	133	2,4	2892	7618	BC 130.2 - 80N/4D [E]	35	26
	52,0	26,73	131	1,8	1832	4460	BC 125.2 - 80N/4D [E]	26	26
	56,2	24,75	121	0,8	1415	3220	BC 102.2 - 80N/4D [E]	20	26
	57,0	24,40	119	2,7	2797	7381	BC 130.2 - 80N/4D [E]	35	26
	58,0	23,96	117	2,0	1776	4322	BC 125.2 - 80N/4D [E]	26	26
	61,1	22,76	111	0,9	1387	3220	BC 102.2 - 80N/4D [E]	20	26
	63,0	22,05	108	2,9	2710	7164	BC 130.2 - 80N/4D [E]	35	26
	64,3	21,61	106	2,2	1724	4196	BC 125.2 - 80N/4D [E]	26	26
	66,2	21,00	103	0,9	1360	3220	BC 102.2 - 80N/4D [E]	20	26
	69,4	20,03	98	3,1	2630	6965	BC 130.2 - 80N/4D [E]	35	26
	70,4	19,73	97	1,1	1377	3220	BC 102.2 - 80N/4D [E]	20	26
	70,9	19,60	96	2,4	1676	4079	BC 125.2 - 80N/4D [E]	26	26
	75,6	18,38	90	2,7	1662	4015	BC 125.2 - 80N/4D [E]	26	26
	76,1	18,28	89	3,3	2555	6780	BC 130.2 - 80N/4D [E]	35	26
	77,9	17,84	87	1,2	1341	3220	BC 102.2 - 80N/4D [E]	20	26
	83,0	16,75	82	3,5	2486	6608	BC 130.2 - 80N/4D [E]	35	26
	85,8	16,21	79	1,3	1307	3220	BC 102.2 - 80N/4D [E]	20	26
	85,8	16,19	79	3,0	1600	3870	BC 125.2 - 80N/4D [E]	26	26
	90,3	15,39	75	3,7	2420	6446	BC 130.2 - 80N/4D [E]	35	26
	93,9	14,80	72	1,4	1275	3182	BC 102.2 - 80N/4D [E]	20	26
	96,5	14,40	70	3,4	1545	3740	BC 125.2 - 80N/4D [E]	26	26
	97,9	14,19	69	3,7	2358	6293	BC 130.2 - 80N/4D [E]	35	26
	102	13,57	66	1,5	1245	3104	BC 102.2 - 80N/4D [E]	20	26
	108	12,91	63	3,8	1494	3622	BC 125.2 - 80N/4D [E]	26	26
	109	12,80	63	1,8	1244	3064	BC 102.2 - 80N/4D [E]	20	26
	117	11,90	58	0,8	943	2180	BC 086.2 - 80N/4D [E]	14	26
	122	11,40	56	2,0	1204	2964	BC 102.2 - 80N/4D [E]	20	26
	126	11,02	54	0,9	924	2159	BC 086.2 - 80N/4D [E]	14	26
	136	10,24	50	2,2	1167	2873	BC 102.2 - 80N/4D [E]	20	26
	136	10,23	50	1,0	906	2114	BC 086.2 - 80N/4D [E]	14	26
	146	9,52	47	1,0	888	2071	BC 086.2 - 80N/4D [E]	14	26
	150	9,26	45	2,4	1133	2791	BC 102.2 - 80N/4D [E]	20	26
	156	8,89	44	1,1	872	2031	BC 086.2 - 80N/4D [E]	14	26
	165	8,41	41	2,6	1101	2714	BC 102.2 - 80N/4D [E]	20	26
	167	8,31	41	1,1	855	1992	BC 086.2 - 80N/4D [E]	14	26
	178	7,79	38	1,2	840	1955	BC 086.2 - 80N/4D [E]	14	26
	181	7,68	38	2,7	1071	2643	BC 102.2 - 80N/4D [E]	20	26
	197	7,04	34	2,9	1043	2577	BC 102.2 - 80N/4D [E]	20	26
	199	6,98	34	1,6	836	1914	BC 086.2 - 80N/4D [E]	14	26
	221	6,30	31	1,7	822	1878	BC 086.2 - 80N/4D [E]	14	26
227	6,13	30	3,8	1010	2482	BC 102.2 - 80N/4D [E]	20	26	
243	5,73	28	1,9	809	1846	BC 086.2 - 80N/4D [E]	14	26	
266	5,23	26	2,0	797	1817	BC 086.2 - 80N/4D [E]	14	26	
289	4,81	24	2,1	786	1791	BC 086.2 - 80N/4D [E]	14	26	
314	4,43	22	2,3	776	1767	BC 086.2 - 80N/4D [E]	14	26	
339	4,10	20	2,4	767	1745	BC 086.2 - 80N/4D [E]	14	26	
365	3,81	19	2,6	759	1726	BC 086.2 - 80N/4D [E]	14	26	
392	3,55	17	2,6	751	1708	BC 086.2 - 80N/4D [E]	14	26	
420	3,31	16	2,7	744	1691	BC 086.2 - 80N/4D [E]	14	26	
448	3,10	15	2,6	737	1675	BC 086.2 - 80N/4D [E]	14	26	
479	2,90	14	2,7	731	1660	BC 086.2 - 80N/4D [E]	14	26	

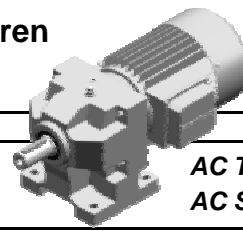

C.2 Drehstrommotoren D - 50 Hz
Einphasen-Wechselstrommotoren E] - 50 Hz

AC Threephase Motors D - 50 Hz
AC Single-Phase Motors [E] - 50 Hz

P	n ₂	i	M _{n2}	f _B	F _{r NL}	F _{r SL}	Typ/Type	m	Maß/Dim.
[kW]	[min ⁻¹]		[Nm]		[N]	[N]		[kg]	Seite/Page
0,75	496	5,73	14	3,8	732	1656	BC 086.2 - 80K/2D	13	26
	543	5,23	13	4,1	724	1637	BC 086.2 - 80K/2D	13	26
	590	4,81	12	4,3	716	1620	BC 086.2 - 80K/2D	13	26
	641	4,43	11	4,6	710	1605	BC 086.2 - 80K/2D	13	26
	693	4,10	10	5,0	704	1591	BC 086.2 - 80K/2D	13	26
	745	3,81	9	5,3	698	1579	BC 086.2 - 80K/2D	13	26
	800	3,55	9	5,4	693	1568	BC 086.2 - 80K/2D	13	26
	858	3,31	8	5,4	689	1558	BC 086.2 - 80K/2D	13	26
	916	3,10	7	5,4	684	1548	BC 086.2 - 80K/2D	13	26
	979	2,90	7	5,5	680	1539	BC 086.2 - 80K/2D	13	26
1,1	27,5	33,42	363	0,9	3268	7650	BC 130.2 - 90L/6D	41	26
	30,3	46,28	330	1,0	3231	7650	BC 130.2 - 90S/4D [E]	38	26
	34,0	41,21	294	1,1	3133	7650	BC 130.2 - 90S/4D [E]	38	26
	37,1	37,77	269	0,9	1818	4806	BC 125.2 - 90S/4D [E]	29	26
	37,8	36,99	264	1,2	3042	7650	BC 130.2 - 90S/4D [E]	38	26
	41,1	34,07	243	1,0	1780	4673	BC 125.2 - 90S/4D [E]	29	26
	41,9	33,42	238	1,3	2956	7650	BC 130.2 - 90S/4D [E]	38	26
	45,3	30,90	220	1,0	1743	4550	BC 125.2 - 90S/4D [E]	29	26
	45,9	30,53	218	1,5	2906	7650	BC 130.2 - 90S/4D [E]	38	26
	49,7	28,15	201	1,1	1707	4434	BC 125.2 - 90S/4D [E]	29	26
	51,5	27,19	194	1,7	2811	7546	BC 130.2 - 90S/4D [E]	38	26
	52,4	26,73	191	1,3	1726	4392	BC 125.2 - 90S/4D [E]	29	26
	57,4	24,40	174	1,8	2723	7314	BC 130.2 - 90S/4D [E]	38	26
	58,4	23,96	171	1,4	1681	4260	BC 125.2 - 90S/4D [E]	29	26
	63,5	22,05	157	2,0	2642	7103	BC 130.2 - 90S/4D [E]	38	26
	64,8	21,61	154	1,5	1637	4138	BC 125.2 - 90S/4D [E]	29	26
	69,9	20,03	143	2,1	2567	6907	BC 130.2 - 90S/4D [E]	38	26
	71,4	19,60	140	1,6	1596	4025	BC 125.2 - 90S/4D [E]	29	26
	76,2	18,38	131	1,8	1597	3969	BC 125.2 - 90S/4D [E]	29	26
	76,6	18,28	130	2,3	2497	6726	BC 130.2 - 90S/4D [E]	38	26
	78,5	17,84	127	0,8	1234	3220	BC 102.2 - 90S/4D [E]	23	26
	83,6	16,75	119	2,4	2431	6556	BC 130.2 - 90S/4D [E]	38	26
	86,4	16,21	116	0,9	1210	3207	BC 102.2 - 90S/4D [E]	23	26
	86,5	16,19	115	2,1	1543	3828	BC 125.2 - 90S/4D [E]	29	26
	90,9	15,39	110	2,5	2369	6397	BC 130.2 - 90S/4D [E]	38	26
	94,6	14,80	106	1,0	1186	3127	BC 102.2 - 90S/4D [E]	23	26
	97,2	14,40	103	2,3	1493	3702	BC 125.2 - 90S/4D [E]	29	26
	98,6	14,19	101	2,5	2310	6246	BC 130.2 - 90S/4D [E]	38	26
	103	13,57	97	1,0	1162	3052	BC 102.2 - 90S/4D [E]	23	26
	104	13,52	96	3,4	2299	6176	BC 130.2 - 90S/4D [E]	38	26
	108	12,91	92	2,6	1447	3587	BC 125.2 - 90S/4D [E]	29	26
	109	12,80	91	1,3	1179	3022	BC 102.2 - 90S/4D [E]	23	26
	116	12,04	86	3,8	2217	5970	BC 130.2 - 90S/4D [E]	38	26
	120	11,64	83	2,8	1404	3482	BC 125.2 - 90S/4D [E]	29	26
	123	11,40	81	1,4	1146	2925	BC 102.2 - 90S/4D [E]	23	26
	133	10,56	75	3,0	1365	3385	BC 125.2 - 90S/4D [E]	29	26
	137	10,24	73	1,5	1114	2838	BC 102.2 - 90S/4D [E]	23	26
	146	9,62	69	3,1	1327	3295	BC 125.2 - 90S/4D [E]	29	26
	147	9,53	68	3,5	1338	3294	BC 125.2 - 90S/4D [E]	29	26
	151	9,26	66	1,6	1085	2758	BC 102.2 - 90S/4D [E]	23	26
166	8,41	60	1,8	1057	2683	BC 102.2 - 90S/4D [E]	23	26	
182	7,68	55	1,9	1030	2614	BC 102.2 - 90S/4D [E]	23	26	
199	7,04	50	2,0	1005	2550	BC 102.2 - 90S/4D [E]	23	26	
229	6,13	44	2,6	983	2462	BC 102.2 - 90S/4D [E]	23	26	
257	5,46	39	2,9	961	2405	BC 102.2 - 90S/4D [E]	23	26	
286	4,90	35	3,1	942	2354	BC 102.2 - 90S/4D [E]	23	26	
316	4,43	32	3,4	924	2309	BC 102.2 - 90S/4D [E]	23	26	
348	4,03	29	3,7	908	2268	BC 102.2 - 90S/4D [E]	23	26	

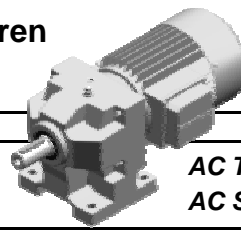

**C.2 Drehstrommotoren D - 50 Hz
Einphasen-Wechselstrommotoren E] - 50 Hz**

**AC Threephase Motors D - 50 Hz
AC Single-Phase Motors [E] - 50 Hz**

P	n ₂	i	M _{n2}	f _B	F _{r NL}	F _{r SL}	Typ/Type	m	Maß/Dim.
[kW]	[min ⁻¹]		[Nm]		[N]	[N]		[kg]	Seite/Page
1,1	379	3,70	26	4,1	897	2235	BC 102.2 - 90S/4D [E]	23	26
	417	3,36	24	4,4	882	2197	BC 102.2 - 90S/4D [E]	23	26
	451	6,30	22	2,4	728	1669	BC 086.2 - 80N/2D	14	26
	457	3,07	22	4,5	869	2164	BC 102.2 - 90S/4D [E]	23	26
	496	5,73	20	2,6	720	1648	BC 086.2 - 80N/2D	14	26
	498	2,81	20	4,5	857	2134	BC 102.2 - 90S/4D [E]	23	26
	541	2,59	18	4,6	845	2106	BC 102.2 - 90S/4D [E]	23	26
	543	5,23	18	2,8	712	1630	BC 086.2 - 80N/2D	14	26
	587	2,39	17	4,5	835	2080	BC 102.2 - 90S/4D [E]	23	26
	590	4,81	17	3,0	706	1614	BC 086.2 - 80N/2D	14	26
	641	4,43	16	3,1	700	1599	BC 086.2 - 80N/2D	14	26
	693	4,10	14	3,4	695	1586	BC 086.2 - 80N/2D	14	26
	745	3,81	13	3,6	690	1574	BC 086.2 - 80N/2D	14	26
	800	3,55	12	3,7	685	1563	BC 086.2 - 80N/2D	14	26
	858	3,31	12	3,7	681	1553	BC 086.2 - 80N/2D	14	26
	916	3,10	11	3,7	677	1543	BC 086.2 - 80N/2D	14	26
	979	2,90	10	3,7	674	1535	BC 086.2 - 80N/2D	14	26
	1010	2,81	10	9,2	782	1942	BC 102.2 - 80N/2D	20	26
	1098	2,59	9	9,2	775	1925	BC 102.2 - 80N/2D	20	26
	1191	2,39	8	9,2	768	1909	BC 102.2 - 80N/2D	20	26
1,5	34,2	41,21	398	0,8	2968	7650	BC 130.2 - 90L/4D [E]	40	26
	38,1	36,99	357	0,9	2893	7650	BC 130.2 - 90L/4D [E]	40	26
	42,2	33,42	323	1,0	2822	7650	BC 130.2 - 90L/4D [E]	40	26
	46,2	30,53	295	1,1	2794	7650	BC 130.2 - 90L/4D [E]	40	26
	50,1	28,15	272	0,8	1537	4341	BC 125.2 - 90L/4D [E]	31	26
	51,9	27,19	262	1,2	2710	7465	BC 130.2 - 90L/4D [E]	40	26
	52,8	26,73	258	0,9	1588	4312	BC 125.2 - 90L/4D [E]	31	26
	57,8	24,40	236	1,3	2632	7240	BC 130.2 - 90L/4D [E]	40	26
	58,9	23,96	231	1,0	1557	4187	BC 125.2 - 90L/4D [E]	31	26
	64,0	22,05	213	1,5	2559	7033	BC 130.2 - 90L/4D [E]	40	26
	65,2	21,61	209	1,1	1525	4071	BC 125.2 - 90L/4D [E]	31	26
	70,4	20,03	193	1,6	2491	6842	BC 130.2 - 90L/4D [E]	40	26
	71,9	19,60	189	1,2	1494	3963	BC 125.2 - 90L/4D [E]	31	26
	76,7	18,38	177	1,4	1516	3917	BC 125.2 - 90L/4D [E]	31	26
	77,1	18,28	176	1,7	2426	6665	BC 130.2 - 90L/4D [E]	40	26
	84,2	16,75	162	1,8	2365	6499	BC 130.2 - 90L/4D [E]	40	26
	87,1	16,19	156	1,5	1471	3781	BC 125.2 - 90L/4D [E]	31	26
	91,6	15,39	149	1,9	2307	6342	BC 130.2 - 90L/4D [E]	40	26
	97,9	14,40	139	1,7	1429	3659	BC 125.2 - 90L/4D [E]	31	26
	99,3	14,19	137	1,9	2252	6194	BC 130.2 - 90L/4D [E]	40	26
	104	13,52	131	2,5	2253	6133	BC 130.2 - 90L/4D [E]	40	26
	109	12,91	125	1,9	1389	3548	BC 125.2 - 90L/4D [E]	31	26
	110	12,80	124	0,9	1095	2972	BC 102.2 - 90L/4D [E]	25	26
	117	12,04	116	2,8	2176	5930	BC 130.2 - 90L/4D [E]	40	26
	121	11,64	112	2,1	1352	3446	BC 125.2 - 90L/4D [E]	31	26
	124	11,40	110	1,0	1071	2880	BC 102.2 - 90L/4D [E]	25	26
	130	10,81	104	3,0	2106	5746	BC 130.2 - 90L/4D [E]	40	26
	134	10,56	102	2,2	1316	3351	BC 125.2 - 90L/4D [E]	31	26
	138	10,24	99	1,1	1047	2797	BC 102.2 - 90L/4D [E]	25	26
	144	9,77	94	3,3	2041	5578	BC 130.2 - 90L/4D [E]	40	26
	147	9,62	93	2,3	1282	3263	BC 125.2 - 90L/4D [E]	31	26
	148	9,53	92	2,6	1300	3266	BC 125.2 - 90L/4D [E]	31	26
	152	9,26	89	1,2	1024	2719	BC 102.2 - 90L/4D [E]	25	26
	159	8,87	86	3,5	1982	5424	BC 130.2 - 90L/4D [E]	40	26
168	8,41	81	1,3	1001	2648	BC 102.2 - 90L/4D [E]	25	26	
168	8,40	81	3,0	1254	3149	BC 125.2 - 90L/4D [E]	31	26	
174	8,10	78	3,6	1926	5280	BC 130.2 - 90L/4D [E]	40	26	
184	7,68	74	1,4	979	2581	BC 102.2 - 90L/4D [E]	25	26	

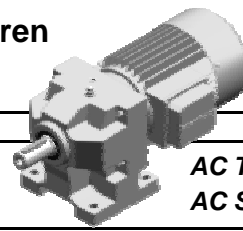

C.2 Drehstrommotoren D - 50 Hz
Einphasen-Wechselstrommotoren E] - 50 Hz

AC Threephase Motors D - 50 Hz
AC Single-Phase Motors [E] - 50 Hz

P	n ₂	i	M _{n2}	f _B	F _{r NL}	F _{r SL}	Typ/Type	m	Maß/Dim.
[kW]	[min ⁻¹]		[Nm]		[N]	[N]		[kg]	Seite/Page
1,5	189	7,47	72	3,3	1212	3045	BC 125.2 - 90L/4D [E]	31	26
	190	7,42	72	3,6	1874	5146	BC 130.2 - 90L/4D [E]	40	26
	200	7,04	68	1,5	958	2519	BC 102.2 - 90L/4D [E]	25	26
	207	6,82	66	3,6	1842	5062	BC 130.2 - 90L/4D [E]	40	26
	211	6,69	65	3,6	1174	2950	BC 125.2 - 90L/4D [E]	31	26
	230	6,13	59	1,9	949	2439	BC 102.2 - 90L/4D [E]	25	26
	234	6,04	58	3,6	1150	2888	BC 125.2 - 90L/4D [E]	31	26
	258	5,46	53	2,1	931	2384	BC 102.2 - 90L/4D [E]	25	26
	288	4,90	47	2,3	915	2335	BC 102.2 - 90L/4D [E]	25	26
	318	4,43	43	2,5	900	2291	BC 102.2 - 90L/4D [E]	25	26
	350	4,03	39	2,7	886	2252	BC 102.2 - 90L/4D [E]	25	26
	382	3,70	36	3,0	877	2220	BC 102.2 - 90L/4D [E]	25	26
	420	3,36	32	3,2	864	2184	BC 102.2 - 90L/4D [E]	25	26
	460	3,07	30	3,3	852	2151	BC 102.2 - 90L/4D [E]	25	26
	502	2,81	27	3,4	841	2122	BC 102.2 - 90L/4D [E]	25	26
	545	2,59	25	3,4	831	2094	BC 102.2 - 90L/4D [E]	25	26
	591	2,39	23	3,3	821	2070	BC 102.2 - 90L/4D [E]	25	26
	611	2,31	22	5,7	980	2448	BC 125.2 - 90L/4D [E]	31	26
	644	4,43	21	5,1	818	2048	BC 102.2 - 90S/2D	24	26
	708	4,03	19	5,5	808	2022	BC 102.2 - 90S/2D	24	26
	771	3,70	18	6,1	800	2000	BC 102.2 - 90S/2D	24	26
849	3,36	16	6,5	791	1977	BC 102.2 - 90S/2D	24	26	
929	3,07	15	6,8	783	1956	BC 102.2 - 90S/2D	24	26	
1014	2,81	13	6,8	775	1937	BC 102.2 - 90S/2D	24	26	
1102	2,59	12	6,8	769	1920	BC 102.2 - 90S/2D	24	26	
1195	2,39	11	6,8	762	1904	BC 102.2 - 90S/2D	24	26	
2,2	52,2	27,19	382	0,8	2518	7329	BC 130.2 - 100L/4D [E]	49	26
	58,2	24,40	343	0,9	2459	7115	BC 130.2 - 100L/4D [E]	49	26
	64,4	22,05	310	1,0	2402	6918	BC 130.2 - 100L/4D [E]	49	26
	70,9	20,03	282	1,1	2347	6736	BC 130.2 - 100L/4D [E]	49	26
	72,4	19,60	275	0,8	1284	3854	BC 125.2 - 100L/4D [E]	40	26
	77,2	18,38	258	0,9	1355	3827	BC 125.2 - 100L/4D [E]	40	26
	77,7	18,28	257	1,2	2293	6565	BC 130.2 - 100L/4D [E]	49	26
	84,8	16,75	235	1,2	2242	6405	BC 130.2 - 100L/4D [E]	49	26
	87,7	16,19	228	1,1	1330	3701	BC 125.2 - 100L/4D [E]	40	26
	92,2	15,39	216	1,3	2192	6254	BC 130.2 - 100L/4D [E]	49	26
	98,6	14,40	202	1,2	1304	3587	BC 125.2 - 100L/4D [E]	40	26
	100	14,19	199	1,3	2144	6111	BC 130.2 - 100L/4D [E]	49	26
	105	13,52	190	1,7	2172	6066	BC 130.2 - 100L/4D [E]	49	26
	110	12,91	181	1,3	1277	3482	BC 125.2 - 100L/4D [E]	40	26
	118	12,04	169	1,9	2103	5869	BC 130.2 - 100L/4D [E]	49	26
	122	11,64	164	1,4	1250	3384	BC 125.2 - 100L/4D [E]	40	26
	131	10,81	152	2,1	2040	5689	BC 130.2 - 100L/4D [E]	49	26
	134	10,56	148	1,5	1223	3294	BC 125.2 - 100L/4D [E]	40	26
	145	9,77	137	2,3	1981	5526	BC 130.2 - 100L/4D [E]	49	26
	148	9,62	135	1,6	1197	3210	BC 125.2 - 100L/4D [E]	40	26
	149	9,53	134	1,8	1229	3220	BC 125.2 - 100L/4D [E]	40	26
	153	9,26	130	0,8	901	2653	BC 102.2 - 100L/4D [E]	34	26
	160	8,87	125	2,4	1925	5374	BC 130.2 - 100L/4D [E]	49	26
	169	8,41	118	0,9	889	2587	BC 102.2 - 100L/4D [E]	34	26
	169	8,40	118	2,0	1192	3108	BC 125.2 - 100L/4D [E]	40	26
	175	8,10	114	2,5	1874	5234	BC 130.2 - 100L/4D [E]	49	26
	185	7,68	108	1,0	877	2525	BC 102.2 - 100L/4D [E]	34	26
	190	7,47	105	2,3	1157	3007	BC 125.2 - 100L/4D [E]	40	26
	191	7,42	104	2,5	1827	5106	BC 130.2 - 100L/4D [E]	49	26
	202	7,04	99	1,0	863	2466	BC 102.2 - 100L/4D [E]	34	26
	208	6,82	96	2,5	1798	5024	BC 130.2 - 100L/4D [E]	49	26
212	6,69	94	2,5	1125	2917	BC 125.2 - 100L/4D [E]	40	26	

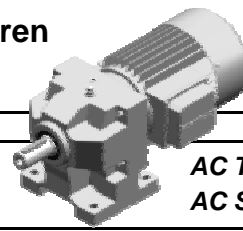

C.2 Drehstrommotoren D - 50 Hz
Einphasen-Wechselstrommotoren E] - 50 Hz

AC Threephase Motors D - 50 Hz
AC Single-Phase Motors [E] - 50 Hz

P	n ₂	i	M _{n2}	f _B	F _{r NL}	F _{r SL}	Typ/Type	m	Maß/Dim.
[kW]	[min ⁻¹]		[Nm]		[N]	[N]		[kg]	Seite/Page
2,2	215	6,62	93	3,6	1808	5010	BC 130.2 - 100L/4D [E]	49	26
	232	6,13	86	1,3	884	2401	BC 102.2 - 100L/4D [E]	34	26
	235	6,04	85	2,5	1105	2858	BC 125.2 - 100L/4D [E]	40	26
	241	5,89	83	3,9	1770	4904	BC 130.2 - 100L/4D [E]	49	26
	249	5,71	80	3,0	1108	2835	BC 125.2 - 100L/4D [E]	40	26
	260	5,46	77	1,5	874	2349	BC 102.2 - 100L/4D [E]	34	26
	282	5,03	71	3,4	1085	2767	BC 125.2 - 100L/4D [E]	40	26
	290	4,90	69	1,6	864	2303	BC 102.2 - 100L/4D [E]	34	26
	318	4,47	63	3,8	1064	2707	BC 125.2 - 100L/4D [E]	40	26
	321	4,43	62	1,7	853	2262	BC 102.2 - 100L/4D [E]	34	26
	353	4,03	57	1,9	844	2225	BC 102.2 - 100L/4D [E]	34	26
	354	4,01	56	3,9	1045	2655	BC 125.2 - 100L/4D [E]	40	26
	384	3,70	52	2,1	840	2196	BC 102.2 - 100L/4D [E]	34	26
	393	3,62	51	3,9	1028	2609	BC 125.2 - 100L/4D [E]	40	26
	423	3,36	47	2,2	830	2162	BC 102.2 - 100L/4D [E]	34	26
	433	3,28	46	3,9	1013	2567	BC 125.2 - 100L/4D [E]	40	26
	463	3,07	43	2,3	821	2131	BC 102.2 - 100L/4D [E]	34	26
	475	2,99	42	3,9	999	2529	BC 125.2 - 100L/4D [E]	40	26
	505	2,81	40	2,3	812	2102	BC 102.2 - 100L/4D [E]	34	26
	520	2,73	38	3,9	986	2495	BC 125.2 - 100L/4D [E]	40	26
	549	2,59	36	2,3	804	2076	BC 102.2 - 100L/4D [E]	34	26
	566	2,51	35	3,9	974	2463	BC 125.2 - 100L/4D [E]	40	26
	586	4,90	34	3,2	808	2063	BC 102.2 - 90L/2D	26	26
	595	2,39	34	2,3	796	2052	BC 102.2 - 100L/4D [E]	34	26
	615	2,31	32	3,9	963	2435	BC 125.2 - 100L/4D [E]	40	26
	648	4,43	31	3,5	798	2034	BC 102.2 - 90L/2D	26	26
	667	2,13	30	3,9	953	2408	BC 125.2 - 100L/4D [E]	40	26
	713	4,03	28	3,8	790	2009	BC 102.2 - 90L/2D	26	26
	777	3,70	26	4,2	784	1989	BC 102.2 - 90L/2D	26	26
	854	3,36	23	4,5	776	1966	BC 102.2 - 90L/2D	26	26
	936	3,07	21	4,6	769	1946	BC 102.2 - 90L/2D	26	26
	1021	2,81	20	4,7	763	1927	BC 102.2 - 90L/2D	26	26
	1110	2,59	18	4,7	757	1911	BC 102.2 - 90L/2D	26	26
	1203	2,39	17	4,6	751	1896	BC 102.2 - 90L/2D	26	26
1244	2,31	16	7,9	897	2251	BC 125.2 - 90L/2D	32	26	
1348	2,13	15	7,9	891	2235	BC 125.2 - 90L/2D	32	26	
3,0	77,7	18,28	350	0,8	2124	6460	BC 130.2 - 100L/4D	52	26
	84,8	16,75	321	0,9	2086	6308	BC 130.2 - 100L/4D	52	26
	92,2	15,39	295	0,9	2047	6163	BC 130.2 - 100L/4D	52	26
	98,6	14,40	276	0,9	1135	3506	BC 125.2 - 100L/4D	43	26
	100	14,19	272	0,9	2009	6026	BC 130.2 - 100L/4D	52	26
	105	13,52	259	1,3	2074	6000	BC 130.2 - 100L/4D	52	26
	110	12,91	247	1,0	1127	3408	BC 125.2 - 100L/4D	43	26
	118	12,04	231	1,4	2016	5809	BC 130.2 - 100L/4D	52	26
	122	11,64	223	1,1	1115	3318	BC 125.2 - 100L/4D	43	26
	131	10,81	207	1,5	1961	5636	BC 130.2 - 100L/4D	52	26
	134	10,56	202	1,1	1101	3233	BC 125.2 - 100L/4D	43	26
	145	9,77	187	1,7	1909	5476	BC 130.2 - 100L/4D	52	26
	148	9,62	184	1,1	1085	3153	BC 125.2 - 100L/4D	43	26
	149	9,53	183	1,3	1140	3173	BC 125.2 - 100L/4D	43	26
	160	8,87	170	1,8	1860	5329	BC 130.2 - 100L/4D	52	26
	169	8,40	161	1,5	1113	3066	BC 125.2 - 100L/4D	43	26
	175	8,10	155	1,8	1814	5191	BC 130.2 - 100L/4D	52	26
	190	7,47	143	1,7	1087	2969	BC 125.2 - 100L/4D	43	26
	191	7,42	142	1,8	1771	5066	BC 130.2 - 100L/4D	52	26
	208	6,82	131	1,8	1746	4987	BC 130.2 - 100L/4D	52	26
	212	6,69	128	1,8	1062	2883	BC 125.2 - 100L/4D	43	26
	215	6,62	127	2,6	1767	4980	BC 130.2 - 100L/4D	52	26

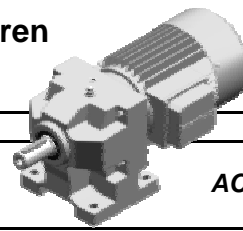

C.2 Drehstrommotoren D - 50 Hz

AC Threephase Motors D - 50 Hz

P	n ₂	i	M _{n2}	f _B	F _{r NL}	F _{r SL}	Typ/Type	m	Maß/Dim.
[kW]	[min ⁻¹]		[Nm]		[N]	[N]		[kg]	Seite/Page
3,0	232	6,13	117	1,0	798	2357	BC 102.2 - 100L/4D	37	26
	235	6,04	116	1,8	1049	2827	BC 125.2 - 100L/4D	43	26
	241	5,89	113	2,9	1734	4877	BC 130.2 - 100L/4D	52	26
	249	5,71	109	2,2	1062	2808	BC 125.2 - 100L/4D	43	26
	260	5,46	105	1,1	798	2310	BC 102.2 - 100L/4D	37	26
	269	5,29	101	3,0	1704	4786	BC 130.2 - 100L/4D	52	26
	275	5,16	99	3,3	1703	4770	BC 130.2 - 100L/4D	52	26
	282	5,03	96	2,5	1044	2743	BC 125.2 - 100L/4D	43	26
	290	4,90	94	1,2	796	2268	BC 102.2 - 100L/4D	37	26
	309	4,59	88	3,7	1673	4680	BC 130.2 - 100L/4D	52	26
	318	4,47	86	2,8	1028	2686	BC 125.2 - 100L/4D	43	26
	321	4,43	85	1,3	793	2230	BC 102.2 - 100L/4D	37	26
	353	4,03	77	1,4	789	2195	BC 102.2 - 100L/4D	37	26
	354	4,01	77	2,9	1013	2636	BC 125.2 - 100L/4D	43	26
	384	3,70	71	1,5	793	2170	BC 102.2 - 100L/4D	37	26
	393	3,62	69	2,9	999	2591	BC 125.2 - 100L/4D	43	26
	423	3,36	64	1,6	788	2138	BC 102.2 - 100L/4D	37	26
	433	3,28	63	2,9	986	2550	BC 125.2 - 100L/4D	43	26
	463	3,07	59	1,7	782	2109	BC 102.2 - 100L/4D	37	26
	475	2,99	57	2,9	974	2514	BC 125.2 - 100L/4D	43	26
	505	2,81	54	1,7	776	2082	BC 102.2 - 100L/4D	37	26
	520	2,73	52	2,9	963	2481	BC 125.2 - 100L/4D	43	26
	549	2,59	50	1,7	771	2057	BC 102.2 - 100L/4D	37	26
	566	2,51	48	2,9	953	2450	BC 125.2 - 100L/4D	43	26
	590	4,90	46	2,4	781	2045	BC 102.2 - 100L/2D	38	26
	595	2,39	46	1,7	766	2034	BC 102.2 - 100L/4D	37	26
	615	2,31	44	2,9	943	2422	BC 125.2 - 100L/4D	43	26
	653	4,43	42	2,6	774	2018	BC 102.2 - 100L/2D	38	26
	667	2,13	41	2,9	934	2396	BC 125.2 - 100L/4D	43	26
	718	4,03	38	2,8	767	1994	BC 102.2 - 100L/2D	38	26
	782	3,70	35	3,1	765	1975	BC 102.2 - 100L/2D	38	26
	860	3,36	32	3,3	759	1954	BC 102.2 - 100L/2D	38	26
	942	3,07	29	3,4	753	1934	BC 102.2 - 100L/2D	38	26
1028	2,81	26	3,4	748	1917	BC 102.2 - 100L/2D	38	26	
1118	2,59	24	3,4	743	1901	BC 102.2 - 100L/2D	38	26	
1212	2,39	22	3,4	738	1886	BC 102.2 - 100L/2D	38	26	
1252	2,31	22	5,8	888	2244	BC 125.2 - 100L/2D	44	26	
1358	2,13	20	5,8	882	2228	BC 125.2 - 100L/2D	44	26	
4,0	106	13,52	343	1,0	1932	5903	BC 130.2 - 112M/4D	58	26
	119	12,04	306	1,1	1890	5721	BC 130.2 - 112M/4D	58	26
	132	10,81	274	1,2	1848	5555	BC 130.2 - 112M/4D	58	26
	135	10,56	268	0,9	917	3145	BC 125.2 - 112M/4D	49	26
	146	9,77	248	1,3	1806	5401	BC 130.2 - 112M/4D	58	26
	149	9,62	244	0,9	918	3072	BC 125.2 - 112M/4D	49	26
	150	9,53	242	1,0	1008	3104	BC 125.2 - 112M/4D	49	26
	161	8,87	225	1,3	1766	5259	BC 130.2 - 112M/4D	58	26
	170	8,40	213	1,1	999	3005	BC 125.2 - 112M/4D	49	26
	177	8,10	205	1,4	1727	5126	BC 130.2 - 112M/4D	58	26
	192	7,47	189	1,3	986	2914	BC 125.2 - 112M/4D	49	26
	193	7,42	188	1,4	1692	5009	BC 130.2 - 112M/4D	58	26
	210	6,82	173	1,4	1673	4933	BC 130.2 - 112M/4D	58	26
	214	6,69	170	1,4	973	2834	BC 125.2 - 112M/4D	49	26
	216	6,62	168	2,0	1709	4935	BC 130.2 - 112M/4D	58	26
	237	6,04	153	1,4	969	2782	BC 125.2 - 112M/4D	49	26
	243	5,89	149	2,2	1683	4836	BC 130.2 - 112M/4D	58	26
	251	5,71	145	1,7	996	2770	BC 125.2 - 112M/4D	49	26
	270	5,29	134	2,3	1658	4749	BC 130.2 - 112M/4D	58	26
	277	5,16	131	2,5	1661	4735	BC 130.2 - 112M/4D	58	26

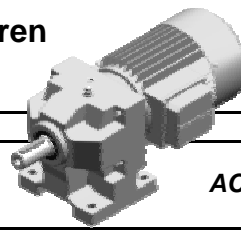

C.2 Drehstrommotoren D - 50 Hz

AC Threephase Motors D - 50 Hz

P	n ₂	i	M _{n2}	f _B	F _{r NL}	F _{r SL}	Typ/Type	m	Maß/Dim.
[kW]	[min ⁻¹]		[Nm]		[N]	[N]		[kg]	Seite/Page
4,0	284	5,03	128	1,9	987	2709	BC 125.2 - 112M/4D	49	26
	311	4,59	117	2,8	1635	4648	BC 130.2 - 112M/4D	58	26
	320	4,47	113	2,1	978	2655	BC 125.2 - 112M/4D	49	26
	347	4,12	105	3,0	1612	4571	BC 130.2 - 112M/4D	58	26
	357	4,01	102	2,2	968	2608	BC 125.2 - 112M/4D	49	26
	384	3,72	95	3,3	1591	4504	BC 130.2 - 112M/4D	58	26
	396	3,62	92	2,2	958	2565	BC 125.2 - 112M/4D	49	26
	423	3,38	86	3,4	1572	4443	BC 130.2 - 112M/4D	58	26
	436	3,28	83	2,2	949	2527	BC 125.2 - 112M/4D	49	26
	463	3,09	78	3,4	1555	4389	BC 130.2 - 112M/4D	58	26
	479	2,99	76	2,2	940	2492	BC 125.2 - 112M/4D	49	26
	505	2,83	72	3,4	1539	4340	BC 130.2 - 112M/4D	58	26
	523	2,73	69	2,2	932	2460	BC 125.2 - 112M/4D	49	26
	550	2,60	66	3,4	1524	4295	BC 130.2 - 112M/4D	58	26
	570	2,51	64	2,2	924	2431	BC 125.2 - 112M/4D	49	26
	596	2,40	61	3,4	1511	4254	BC 130.2 - 112M/4D	58	26
	620	2,31	59	2,2	916	2404	BC 125.2 - 112M/4D	49	26
	645	2,22	56	3,4	1499	4217	BC 130.2 - 112M/4D	58	26
	672	2,13	54	2,2	909	2379	BC 125.2 - 112M/4D	49	26
	799	3,62	45	4,4	911	2340	BC 125.2 - 112M/2D	50	26
881	3,28	41	4,4	903	2315	BC 125.2 - 112M/2D	50	26	
967	2,99	38	4,4	895	2292	BC 125.2 - 112M/2D	50	26	
1058	2,73	34	4,4	889	2272	BC 125.2 - 112M/2D	50	26	
1153	2,51	31	4,4	882	2253	BC 125.2 - 112M/2D	50	26	
1252	2,31	29	4,4	877	2236	BC 125.2 - 112M/2D	50	26	
1358	2,13	27	4,4	872	2221	BC 125.2 - 112M/2D	50	26	

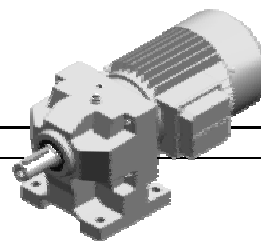

D.1 Ausführungsarten
Designs

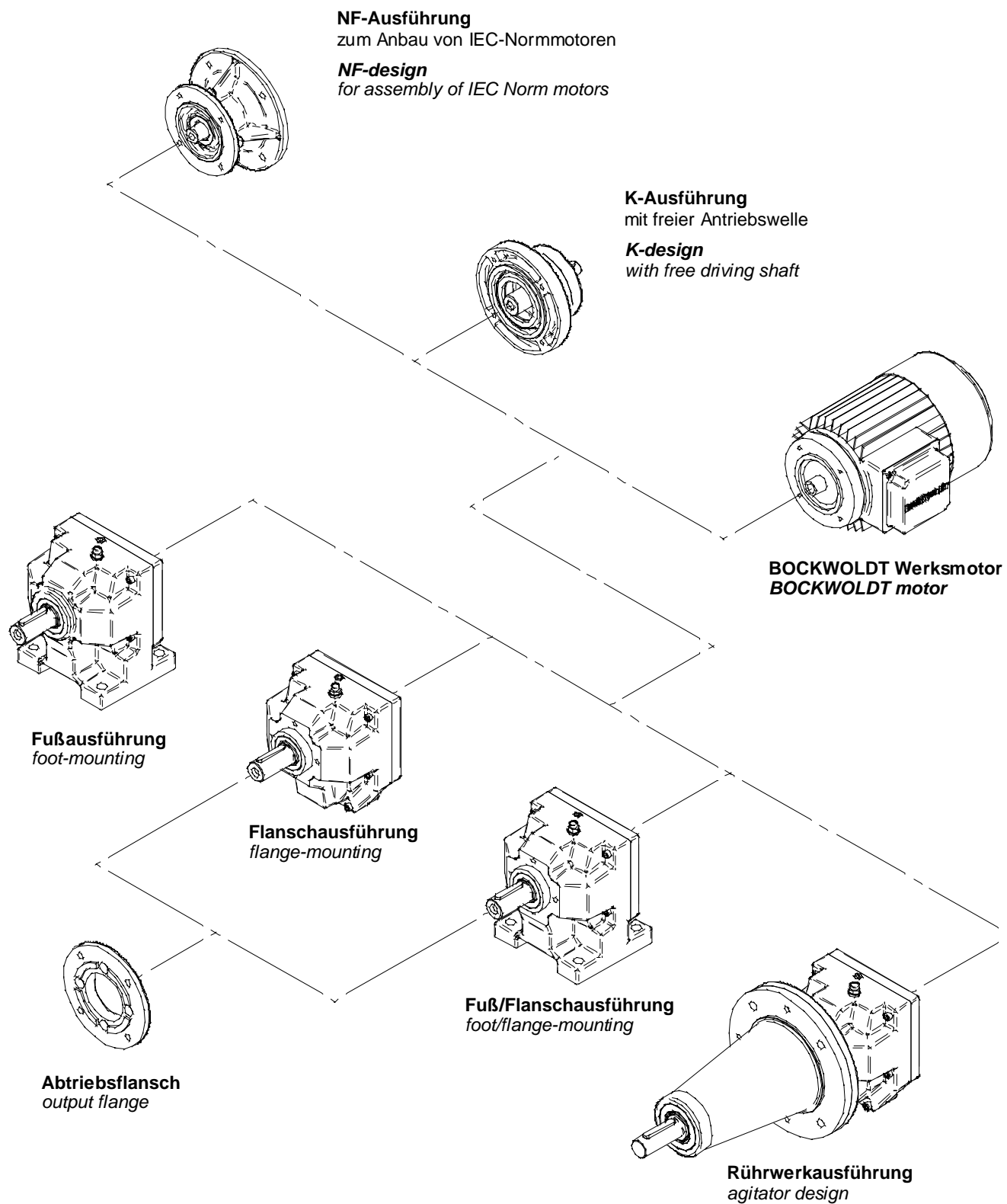

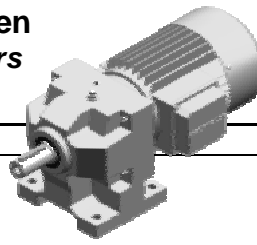

D.2 2-stufig
2-stages

Fußausführung
Foot-Mounting

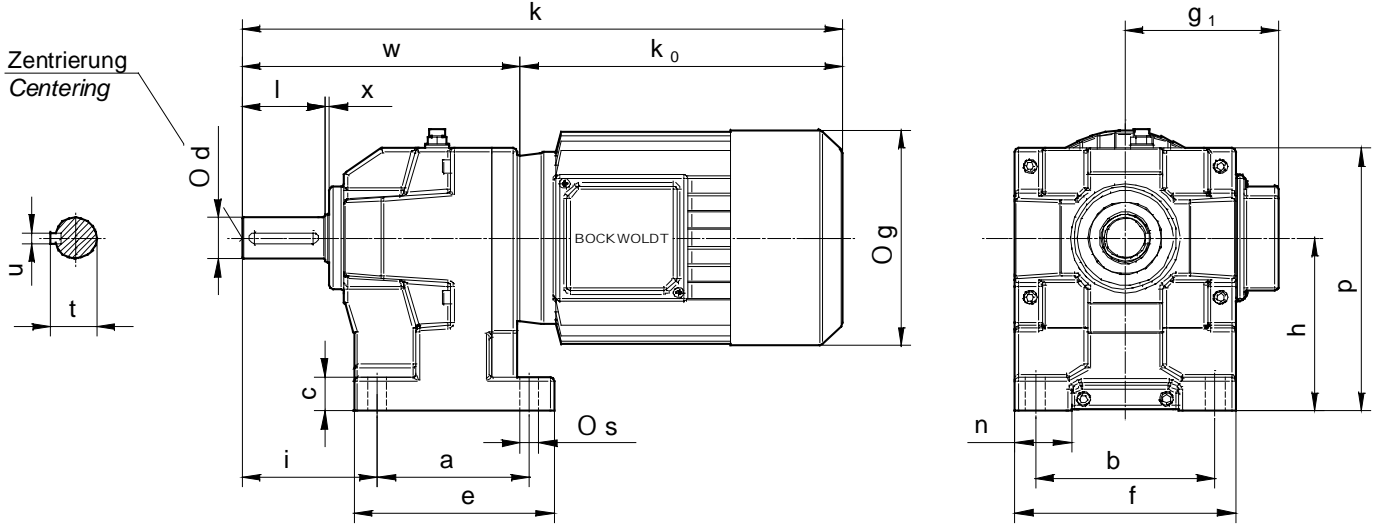

Typ Type	Abmessungen Getriebemotor Dimensions Helical Geared Motors																			Zentrg. Centg.	
	a	b	c	Ø d _{k6} x l	e	f	Ø g	g ₁	h	i	k	k ₀	n	p	Ø s	t	u	w	x		
BC 086.2.A - 63 / D 71 / D 80 / D							125	111			347	197									
	83	100	16	Ø 20 x 40	105	120	148	126	86	67	373	223	28	137	10	22,5	6	150	2	DS M 6	
								160	142			405	255								
BC 102.2.A - 63 / D 71 / D 80 / D 90 S / D 90 L / D 100 L / D							125	111			368	197									
							148	126			394	223									
	100	105	21	Ø 25 x 50	122	135	160	142	102	77,5	426	255	35	162	10	28	8	171	2	DS M 10	
							193	160			461	290									
							193	160			461	290									
BC 125.2.A - 63 / D 71 / D 80 / D 90 S / D 90 L / D 100 L / D 112 M / D							125	111			398	197									
							148	126			424	223									
							160	142			456	255									
	110	130	24	Ø 30 x 60	142	160	193	160	125	97	491	290	41	190	14	33	8	201	3	DS M 10	
							193	160			491	290									
BC 130.2.A - 71 / D 80 / D 90 S / D 90 L / D 100 L / D 112 M / D							148	126			470	223									
							160	142			502	255									
							193	160			537	290									
	145	150	30	Ø 35 x 70	180	180	193	160	130	115	537	290	35	205	14	38	10	247	3	DS M 12	
							220	165			562	315									
						232	188			583	336										

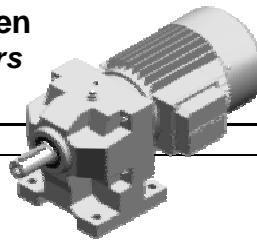

D.2 2-stufig
2-stages

Flanschausführung
Flange-Mounting

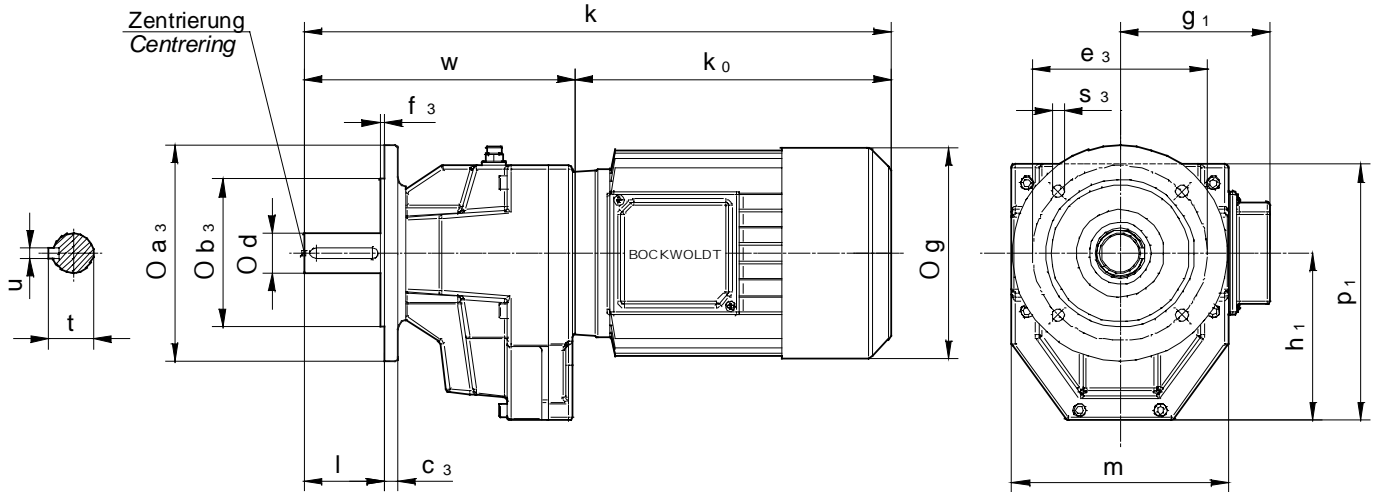

Typ Type	Abmessungen Getriebemotor Dimensions Helical Geared Motors											Abmessungen Abtriebsflansche Dimensions Output Flanges																		
	$\varnothing d_{k6} \times l$	$\varnothing g$	g_1	h_1	k	k_0	m	p_1	t	u	w	Zentr.-Centg.	$\varnothing a_3$	$\varnothing b_3$	c_3	$\varnothing e_3$	f_3	$\varnothing s_3$												
BC 086.2.B - 63 / D 71 / D 80 / D	$\varnothing 20 \times 40$	125	111		347	197							DS M 6	120	80	10	100	3	4 x $\varnothing 7$											
		148	126	85	373	223	120	136	22,5	6	150	140								95	10	115	3	4 x $\varnothing 9$						
		160	142		405	255														160	110	10	130	3,5	4 x $\varnothing 9$					
BC 102.2.B - 63 / D 71 / D 80 / D 90 S / D 90 L / D 100 L / D	$\varnothing 25 \times 50$	125	111		368	197							DS M 10	120	80	10	100	3	4 x $\varnothing 7$											
		148	126		394	223														140	95	10	115	3	4 x $\varnothing 9$					
		160	142	101	426	255	135	161	28	8	171	160								189	33	8	201	DS M 10	160	110	10	130	3,5	4 x $\varnothing 9$
		193	160		461	290															200	130	12	165	3,5	4 x $\varnothing 11$				
		193	160		461	290															250	180	15	215	4	4 x $\varnothing 14$				
BC 125.2.B - 63 / D 71 / D 80 / D 90 S / D 90 L / D 100 L / D 112 M / D	$\varnothing 30 \times 60$	125	111		398	197							DS M 10	140	95	10	115	3	4 x $\varnothing 9$											
		148	126		424	223														160	110	10	130	3,5	4 x $\varnothing 9$					
		160	142		456	255															200	130	12	165	3,5	4 x $\varnothing 11$				
		193	160	124	491	290	160	189	33	8	201	DS M 10								200	130	12	165	3,5	4 x $\varnothing 11$					
		193	160		491	290															250	180	15	215	4	4 x $\varnothing 14$				
		220	165		516	315																								
BC 130.2.B - 71 / D 80 / D 90 S / D 90 L / D 100 L / D 112 M / D	$\varnothing 35 \times 70$	148	126		470	223							DS M 12	160	110	16	130	3,5	4 x $\varnothing 9$											
		160	142		502	255														200	130	12	165	3,5	4 x $\varnothing 11$					
		193	160	128	537	290	180	203	38	10	247	DS M 12								200	130	12	165	3,5	4 x $\varnothing 11$					
		193	160		537	290															250	180	16	215	4	4 x $\varnothing 14$				
		220	165		562	315																								
232	188		583	336																										

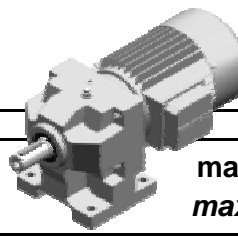

E.1 2-stufig
2-stages

Übersetzungen und
Ratios and

max. Abtriebsdrehmomente
max. Output Torques

BC	2-stufig 2-stages	Gewicht Weight [kg]	Maße Seite Dim. see Page	
	086	BC 086 F	3,2	---
	BC 086 K	6,2	32	
	BC 086 NF	11,2	30	
i	$n_1 = 1380 \text{ min}^{-1}$ [4-polig / 4 poles ; 50 Hz] $f_B = 1,0$			
	n_2 [min^{-1}]	$M_{2 \text{ max.}}$ [Nm]	$P_{1 \text{ max.}}$ [kW]	P_{therm^*} [kW]
50,82	27,2	54	0,16	-
45,87	30,1	53	0,18	-
41,68	33,1	52	0,19	-
38,09	36,2	51	0,20	-
34,97	39,5	50	0,22	-
32,25	42,8	49	0,23	-
29,85	46,2	49	0,25	-
27,71	49,8	48	0,26	-
25,80	53,5	47	0,28	-
24,08	57,3	46	0,29	-
22,52	61,3	45	0,30	-
21,11	65,4	45	0,32	-
18,75	73,6	54	0,44	-
16,93	81,5	53	0,48	-
15,38	89,7	52	0,51	-
14,06	98,2	51	0,55	-
12,91	106,9	50	0,59	-
11,90	115,9	49	0,63	-
11,02	125,3	49	0,68	-
10,23	134,9	48	0,71	-
9,52	144,9	47	0,75	-
8,89	155,3	46	0,79	-
8,31	166,0	45	0,82	-
7,79	177,1	45	0,88	-
6,98	197,6	54	1,18	-
6,30	218,9	53	1,28	-
5,73	241,0	52	1,38	-
5,23	263,7	51	1,48	-
4,81	287,1	50	1,58	-
4,43	311,4	49	1,68	-
4,10	336,5	49	1,82	-
3,81	362,4	48	1,92	-
3,55	389,2	46	1,97	-
3,31	417,0	43	1,98	-
3,10	445,8	40	1,97	-
2,90	475,7	38	1,99	-

BC	2-stufig 2-stages	Gewicht Weight [kg]	Maße Seite Dim. see Page	
	102	BC 102 F	9,2	---
	BC 102 K	12,2	32	
	BC 102 NF	19,2	30	
i	$n_1 = 1380 \text{ min}^{-1}$ [4-polig / 4 poles ; 50 Hz] $f_B = 1,0$			
	n_2 [min^{-1}]	$M_{2 \text{ max.}}$ [Nm]	$P_{1 \text{ max.}}$ [kW]	P_{therm^*} [kW]
51,00	27,1	115	0,34	-
45,00	30,7	115	0,39	-
40,09	34,4	112	0,42	-
36,00	38,3	110	0,46	-
32,54	42,4	108	0,50	-
29,57	46,7	105	0,54	-
27,00	51,1	103	0,58	-
24,75	55,8	101	0,62	-
22,76	60,6	99	0,66	-
21,00	65,7	96	0,70	-
19,73	69,9	110	0,85	-
17,84	77,4	108	0,92	-
16,21	85,1	105	0,99	-
14,80	93,2	103	1,06	-
13,57	101,7	11	0,12	-
12,80	107,8	115	1,37	-
11,40	121,0	112	1,49	-
10,24	134,8	110	1,63	-
9,26	149,1	108	1,77	-
8,41	164,1	105	1,90	-
7,68	179,7	103	2,04	-
7,04	196,0	101	2,18	-
6,13	225,3	115	2,86	-
5,46	252,9	112	3,12	-
4,90	281,6	110	3,00	-
4,43	311,6	108	3,00	-
4,03	342,9	105	3,00	-
3,70	373,4	108	3,00	-
3,36	410,9	105	3,00	-
3,07	450,0	99	3,00	-
2,81	490,9	91	3,00	-
2,59	533,7	84	3,00	-
2,39	578,6	77	3,00	-

Weitere Übersetzungen, Sonderabtriebswellen und schwere Lagerung auf Anfrage lieferbar
Additional ratios, special output shafts and heavy bearings are available on request.

Geringere und höhere Antriebsdrehzahlen als die angegebenen Werte n_1 sind einsetzbar. Erbitten Rückfrager
Lower and higher inputs than the given speeds n_1 are possible. Please enquire before application.

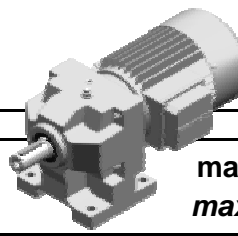

E.1 2-stufig
2-stages

Übersetzungen und
Ratios and

max. Abtriebsdrehmomente
max. Output Torques

BC	2-stufig 2-stages	Gewicht Weight [kg]	Maße Seite Dim. see Page		
	125	BC 125 F	15,1	---	
	BC 125 K	20,5	32		
	BC 125 NF	25,1	30		
i	$n_1 = 1380 \text{ min}^{-1}$ [4-polig / 4 poles ; 50 Hz] $f_B = 1,0$				
	n_2 [min^{-1}]	$M_{2 \text{ max.}}$ [Nm]	$P_{1 \text{ max.}}$ [kW]	P_{therm^*} [kW]	
	53,79	25,7	240	0,68	-
	47,38	29,1	240	0,77	-
	42,14	32,8	240	0,87	-
	37,77	36,5	240	0,97	-
	34,07	40,5	235	1,05	-
	30,90	44,7	229	1,13	-
	28,15	49,0	224	1,21	-
	26,73	51,6	240	1,37	-
	23,96	57,6	240	1,52	-
	21,61	63,9	235	1,65	-
	19,60	70,4	229	1,78	-
	18,38	75,1	240	1,99	-
	16,19	85,2	240	2,25	-
	14,40	95,8	240	2,54	-
	12,91	106,9	240	2,83	-
	11,64	118,5	235	3,07	-
	10,56	130,7	229	3,30	-
	9,62	143,4	210	3,32	-
	9,53	144,8	240	3,83	-
	8,40	164,4	240	4,35	-
	7,47	184,8	240	4,89	-
	6,69	206,2	235	5,34	-
	6,04	228,6	212	5,34	-
	5,71	241,8	240	6,40	5,50
	5,03	274,5	240	7,26	5,50
	4,47	308,6	240	8,16	5,50
	4,01	344,3	221	8,39	5,50
	3,62	381,7	199	8,37	5,50
	3,28	420,9	181	8,40	5,50
	2,99	461,9	165	8,40	5,50
	2,73	505,0	151	8,41	5,50
	2,51	550,3	138	8,37	5,50
	2,31	598,1	127	8,37	5,50
	2,13	648,3	117	8,36	5,50

BC	2-stufig 2-stages	Gewicht Weight [kg]	Maße Seite Dim. see Page		
	130	BC 130 F	24,1	---	
	BC 130 K	29,5	32		
	BC 130 NF	29,1	30		
i	$n_1 = 1400 \text{ min}^{-1}$ [4-polig / 4 poles ; 50 Hz] $f_B = 1,0$				
	n_2 [min^{-1}]	$M_{2 \text{ max.}}$ [Nm]	$P_{1 \text{ max.}}$ [kW]	P_{therm^*} [kW]	
	46,28	30,3	330	1,10	-
	41,21	34,0	323	1,21	-
	36,99	37,8	317	1,32	-
	33,42	41,9	310	1,43	-
	30,53	45,9	330	1,67	-
	27,19	51,5	323	1,83	-
	24,40	57,4	317	2,00	-
	22,05	63,5	310	2,17	-
	20,03	69,9	303	2,33	-
	18,28	76,6	296	2,50	-
	16,75	83,6	290	2,67	-
	15,39	90,9	278	2,79	-
	14,19	98,6	256	2,78	-
	13,52	103,5	330	3,77	-
	12,04	116,2	323	4,14	-
	10,81	129,5	317	4,53	-
	9,77	143,4	310	4,90	-
	8,87	157,8	303	5,27	-
	8,10	172,9	285	5,43	-
	7,42	188,7	261	5,43	-
	6,82	205,3	240	5,43	-
	6,62	211,6	330	7,70	-
	5,89	237,7	323	8,46	-
	5,29	264,8	306	8,93	-
	5,16	271,4	330	9,87	9,20
	4,59	304,8	323	10,9	9,20
	4,12	339,6	317	11,9	9,20
	3,72	375,9	310	12,8	9,20
	3,38	413,8	289	13,2	9,20
	3,09	453,4	264	13,2	9,20
	2,83	494,9	242	13,2	9,20
	2,60	538,3	222	13,2	9,20
	2,40	583,9	205	13,2	9,20
	2,22	631,8	189	13,2	9,20

Weitere Übersetzungen, Sonderabtriebswellen und schwere Lagerung auf Anfrage lieferbar
 Additional ratios, special output shafts and heavy bearings are available on request.

Geringere und höhere Antriebsdrehzahlen als die angegebenen Werte₁ sind einsetzbar. Erbitten Rückfrager
 Lower and higher inputs than the given speeds n_1 are possible. Please enquire before application.

* Erläuterungen zur Thermischen Grenzleistung P_{therm} siehe Seite 120, Katalog

* Please refer to the commentary appertaining to thermal power limit P_{therm} on page 120, catalogue 3

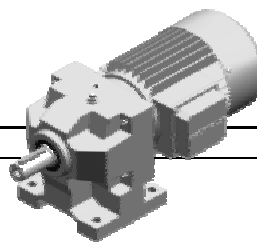

F.1 2-stufig 2-stages Typ NF Type NF Fußausführung Foot-Mounting

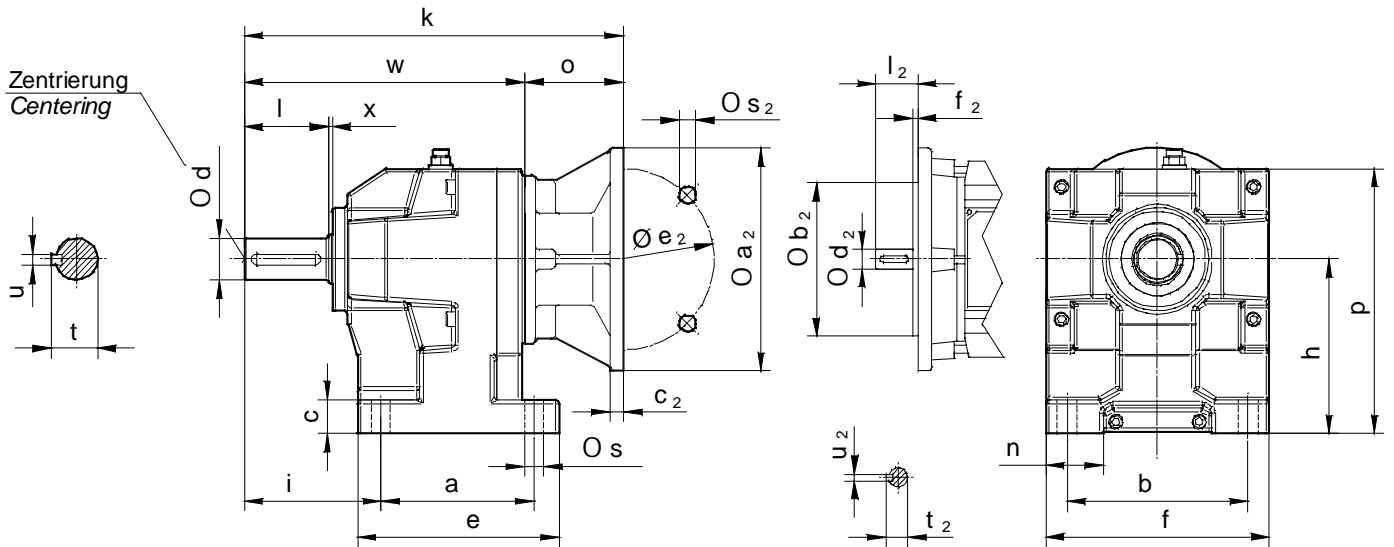

Typ Type	Abmessungen Getriebe Dimensions Helical Gear Boxes																											
	a	Ø a ₂	b	Ø b ₂	c	c ₂	Ø d x l	Ø d ₂ x l ₂	e	Ø e ₂	f	f ₂	h	i	k	n	o	p	Ø s	Ø s ₂	t	t ₂	u	u ₂	w	x	Zentrg. Centg.	
BC 086.2.A NF	63	140	95		8			Ø 11 x 23	115	3					213	63				9		12,5	4					
	71	160	110		10		Ø 20 x	Ø 14 x 30	130	3,5					221	71				9		16	5					DS
	80	200	130	16	10	40	Ø 19 x 40		105	165	120	3,5	86	67	240	28	90	137	10	11	22,5	21,5	6	6	150	2	M 6	
	90	200	130		10		Ø 24 x 50			165		3,5			240		90			11		27	8					
BC 102.2.A NF	63	140	95		8			Ø 11 x 23	115	3					234	63				9		12,5	4					
	71	160	110		10		Ø 14 x 30		130	3,5					242	71				9		16	5					DS
	80	200	130	21	10	Ø 25 x	Ø 19 x 40		122	165	135	3,5	102	77,5	261	35	90	162	10	11	28	21,5	8	6	171	2	M 10	
	90	200	130		10	50	Ø 24 x 50			165		3,5			261		90			11		27	8	8				
	100	250	180		12		Ø 28 x 60			215		4			283		112			14		31	8					
112	250	180		12		Ø 28 x 60			215		4			283		112			14		31	8						
BC 125.2.A NF	63	140	95		8			Ø 11 x 23	115	3					264	63				9		12,5	4					
	71	160	110		10		Ø 14 x 30		130	3,5					272	71				9		16	5					DS
	80	200	130	24	10	Ø 30 x	Ø 19 x 40		142	165	160	3,5	125	97	291	41	90	190	14	11	33	21,5	8	6	201	3	M 10	
	90	200	130		10	60	Ø 24 x 50			165		3,5			291		90			11		27	8	8				
	100	250	180		12		Ø 28 x 60			215		4			313		112			14		31	8					
112	250	180		12		Ø 28 x 60			215		4			313		112			14		31	8						
BC 130.2.A NF	80	200	130		10		Ø 19 x 40		165		3,5				337	90				11		21,5	6					DS
	90	200	130	30	10	Ø 35 x	Ø 24 x 50		165		3,5				337	90				11		27	8	8	247	3	M 12	
	100	250	180		12	70	Ø 28 x 60		215		4		130	115	359	35	112	205	14	14	38	31	10	8				
	112	250	180		12		Ø 28 x 60		215		4				359		112			14		31	8					

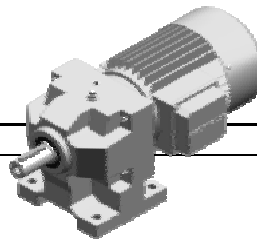

F.1 2-stufig 2-stages **Typ NF Type NF** **Flanschausführung Flange-Mounting**

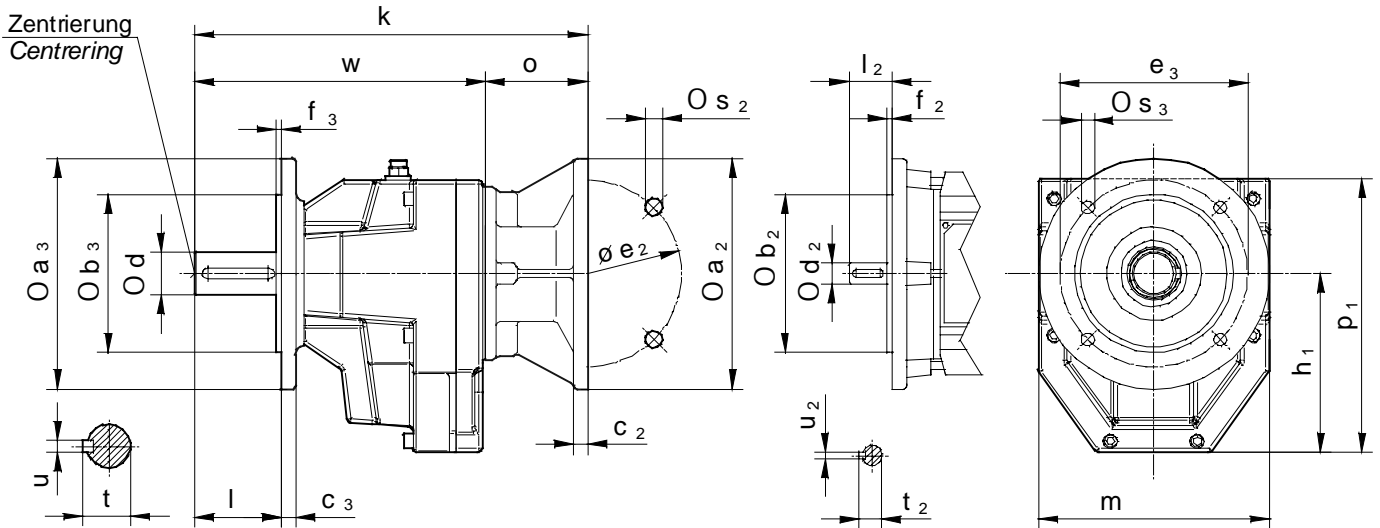

Typ Type	Abmessungen Getriebe Dimensions Helical Gear Boxes																		Abtr.flansche Output Flanges		
	∅ a ₂	∅ b ₂	c ₂	∅ d x l	∅ d ₂ x l ₂	∅ e ₂	f ₂	h ₁	k	m	o	p ₁	∅ s ₂	t	t ₂	u	u ₂	w	Zentrg. Centrg.	∅ a ₃	
BC 086.2.B NF	63	140	95	8		∅ 11 x 23	115	3	213	63	9	9	12,5	4						DS	120 140 160 200
	71	160	110	10		∅ 14 x 30	130	3,5	221	71	9	9	16	5						M 6	
	80	200	130	10	∅ 20 x 40	∅ 19 x 40	165	3,5	240	120	90	11	22,5	6	6	6	150				
	90	200	130	10		∅ 24 x 50	165	3,5	240		90	11	27	8							
BC 102.2.B NF	63	140	95	8		∅ 11 x 23	115	3	234	63	9	9	12,5	4						DS	120 140 160 200
	71	160	110	10		∅ 14 x 30	130	3,5	242	71	9	9	16	5						M 10	
	80	200	130	10		∅ 19 x 40	165	3,5	261	135	90	11	21,5	6	6	6	171				
	90	200	130	10	∅ 25 x 50	∅ 24 x 50	165	3,5	261		90	11	27	8	8	8					
	100	250	180	12		∅ 28 x 60	215	4	283	112	112	14	31	8							
112	250	180	12		∅ 28 x 60	215	4	283	112	112	14	31	8								
BC 125.2.B NF	63	140	95	8		∅ 11 x 23	115	3	264	63	9	9	12,5	4						DS	140 160 200 250
	71	160	110	10		∅ 14 x 30	130	3,5	272	71	9	9	16	5						M 10	
	80	200	130	10		∅ 19 x 40	165	3,5	291	160	90	11	21,5	6	6	6	201				
	90	200	130	10	∅ 30 x 60	∅ 24 x 50	165	3,5	291		90	11	27	8	8	8					
	100	250	180	12		∅ 28 x 60	215	4	313	112	112	14	31	8							
112	250	180	12		∅ 28 x 60	215	4	313	112	112	14	31	8								
BC 130.2.B NF	80	200	130	10		∅ 19 x 40	165	3,5	337	180	90	11	21,5	6						DS	160 200 250
	90	200	130	10		∅ 24 x 50	165	3,5	337		90	11	27	8	8	8	247				
	100	250	180	12	∅ 35 x 70	∅ 28 x 60	215	4	359	180	112	203	31	10	8	8				M 12	
	112	250	180	12		∅ 28 x 60	215	4	359		112	14	31	8							

Dimensions Output Flanges see Page 27

Abmessungen Abtriebsflansche siehe Seite 27

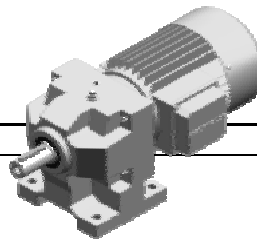

F.2 2-stufig 2-stages	Typ K Type K		Fußausführung Foot-Mounting
---------------------------------	------------------------	--	---------------------------------------

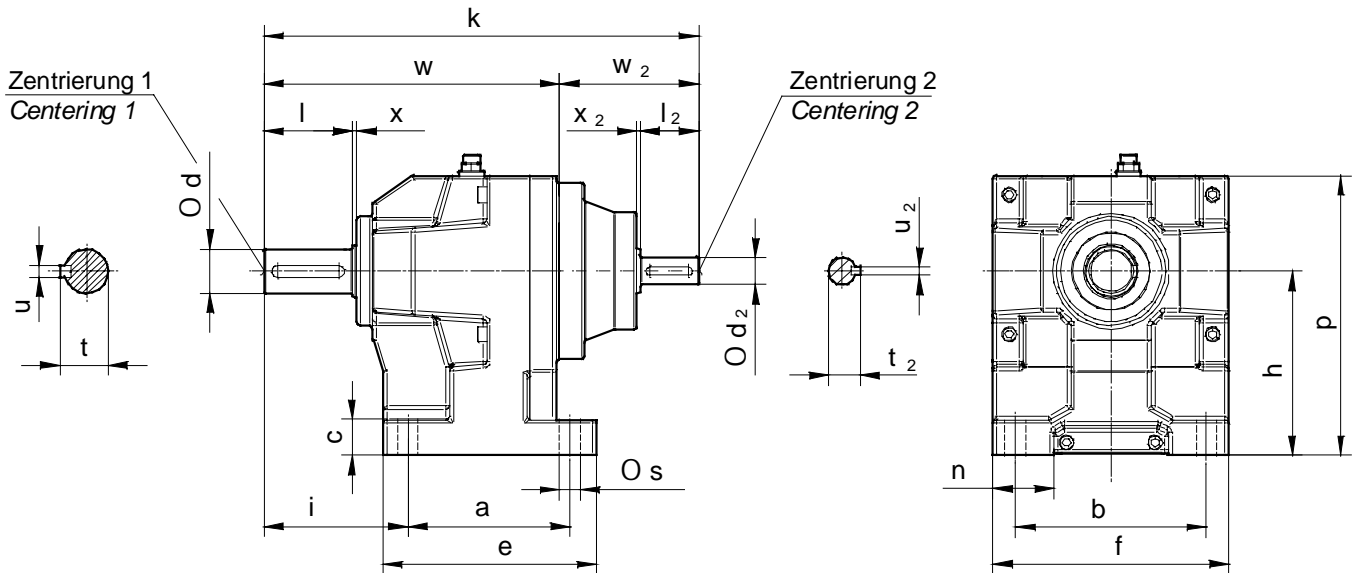

Typ Type	Abmessungen Getriebe Dimensions Helical Gear Boxes																		Zentrg. 1 Centg. 1	Zentrg. 2 Centg. 2			
	a	b	c	Ø d x l	Ø d ₂ x l ₂	e	f	h	i	k	n	p	Ø s	t	t ₂	u	u ₂	w			w ₂	x	x ₂
BC 086.2.A K	83	100	16	Ø 20 x 40	Ø 14 x 30	105	120	86	67	239	28	137	10	22,5	16	6	5	150	89	2	2	DS M 6	DS M 5
BC 102.2.A K	100	105	21	Ø 25 x 50	Ø 14 x 30	122	135	102	77,5	260	35	162	10	28	16	8	5	171	89	2	2	DS M 10	DS M 5
BC 125.2.A K	110	130	24	Ø 30 x 60	Ø 19 x 40	142	160	125	97	313	41	190	14	33	21,5	8	6	201	112	3	2	DS M 10	DS M 6
BC 130.2.A K	145	150	30	Ø 35 x 70	Ø 19 x 40	180	180	130	115	359	35	205	14	38	21,5	10	6	247	112	3	2	DS M 12	DS M 6

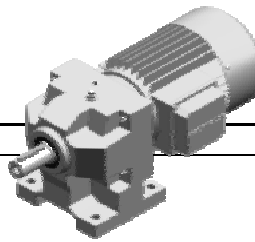

G.1 Flanschausführung ohne Flansch (B 14)
Flange-Mounting without Flange (B 14)

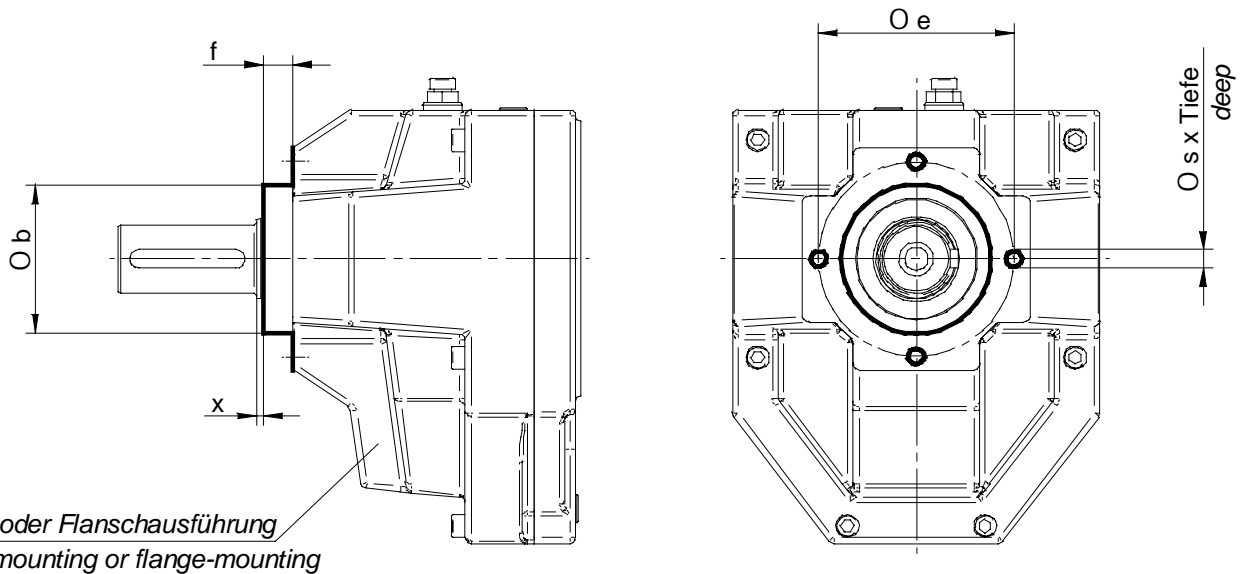

Typ Type	Ø b	Ø e	f	Ø s x Tiefe deep	x
BC 086 .2.BoF	55 h 6	70	11	4 x M 6 x 12	2
BC 102 .2.BoF	55 h 6	70	11	4 x M 6 x 12	2
BC 125 .2.BoF	65 h 6	85	13	4 x M 8 x 14	3
BC 130 .2.BoF	78 h 6	95	20	4 x M 8 x 14	3



BC Stirnradgetriebemotor

○ Flanschausführung ohne Flansch

BoF

BC Helical Geared Motor

○ flange-mounting, without flange

BoF



powered by:
BOCKWOLDT
GmbH & Co. KG

Sehmsdorfer Str. 43-53
D-23843 Bad Oldesloe

Phone:

+ 49 4531 8906-0

Fax:

+ 49 4531 8906-79

E-mail:

info@bockwoldt.de

Internet:

www.bockwoldt.de

☎ 24h-Hotline:

+ 49 160 74 14 794

BOCKWOLDT
GETRIEBEMOTORENWERK